

## **PARAMETRIC DESIGN**

Marjoleine MOOIJMAN, Sara MOTWANI, Joel MUHANGI, Ananya NARENDRA, Ina  
NATSEVA, Claudia NAVARRO CANOVAS  
3<sup>rd</sup> year students MEng Engineering and Architectural Design  
Mechanics of Buildings  
Academic Year 2022 - 2023

## Table of Contents

<b>1. INTRODUCTION</b> .....	<b>4</b>
<b>2.1. Initial hand checks</b> .....	<b>5</b>
2.1.1. Beams .....	6
2.1.2. Columns .....	7
2.1.3. Results .....	7
<b>3. TRIANGULAR FRAME</b> .....	<b>9</b>
<b>3.1. Initial hand checks</b> .....	<b>10</b>
3.1.1. Results .....	11
<b>4. RHOMBOID FRAME</b> .....	<b>12</b>
<b>4.1. Initial hand checks</b> .....	<b>13</b>
4.1.1. Results .....	13
<b>5. BHoM ANALYSIS</b> .....	<b>14</b>
<b>6. ROBOT ANALYSIS</b> .....	<b>15</b>
<b>6.1. Rectangular frame</b> .....	<b>15</b>
<b>6.2. Triangular frame</b> .....	<b>17</b>
<b>6.3. Rhomboid frame</b> .....	<b>18</b>
<b>6.4. Comparison</b> .....	<b>19</b>
<b>7. CONCLUSION</b> .....	<b>19</b>
<b>APPENDICES</b> .....	<b>20</b>
<b>1. RECTANGULAR FRAME</b> .....	<b>20</b>
<b>1.1. Footprint and gridlines</b> .....	<b>20</b>
<b>1.2. Columns and Beams</b> .....	<b>20</b>
1.2.1. Beams .....	20
1.2.2. Columns .....	21
<b>1.3. Sizing</b> .....	<b>21</b>
1.3.1. Preliminary beam sizing.....	21
1.3.2. Preliminary column sizing .....	22
<b>2. TRIANGULAR FRAME</b> .....	<b>22</b>
<b>2.1. Footprint and gridlines</b> .....	<b>22</b>
<b>2.2. Columns and Beams</b> .....	<b>23</b>
2.2.1. Beams .....	23
2.2.2. Columns .....	24
<b>2.3. Sizing</b> .....	<b>24</b>
<b>3. RHOMBOID FRAME</b> .....	<b>25</b>
<b>3.1. Footprint and gridlines</b> .....	<b>25</b>
<b>3.2. Columns and Beams</b> .....	<b>26</b>
3.2.1. Beams .....	26
3.2.2. Columns .....	26
<b>3.3. Sizing</b> .....	<b>26</b>
<b>3.4. BHoM computation</b> .....	<b>27</b>
3.4.1. Assigning properties .....	27

3.5. *Loads* ..... 27

## 1. INTRODUCTION

Using Grasshopper, BHoM and Autodesk Robot (an FEA software) structural analysis was performed on a structural frame with the footprint shown in *Figure 1*. Iterations and permutations were performed for structural optimisation of the building frame. Three iterations were made where three different beam patterns explored: square, rhomboid, and triangular. A final optimal structure was then identified considering benchmarks and set targets. This report will discuss the methodology used to realise optimisation for the footprint provided.

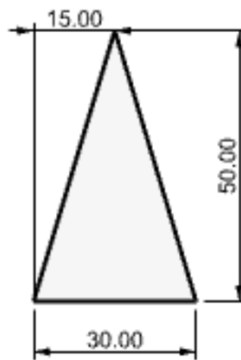

*Figure 1 - Building footprint*

## 2. RECTANGULAR FRAME

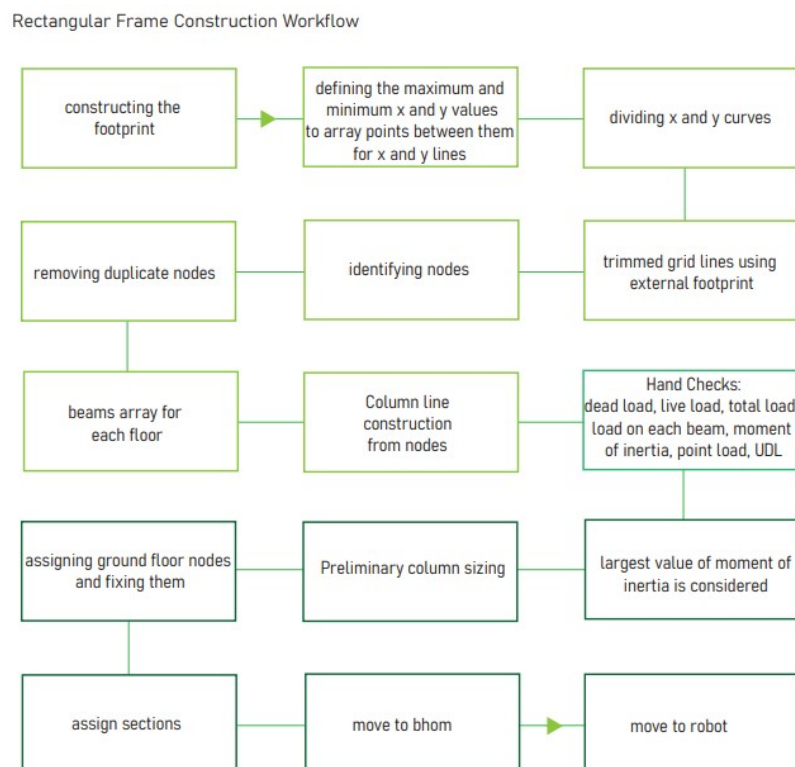

*Figure 2 - Square grid workflow*

A rectangular beam patterned frame (*Figure 3*) was made using Grasshopper (*Figure 2*). The full script is found in *Appendix 1*. To create the frame a rectangular grid was made which was later trimmed by the footprint of the building. After, nodes were identified at every intersection of primary and secondary beams, the beam pattern was arrayed for the stories and then columns were created at each node. For material efficiency, cost efficiency and a more regular bay system, external cantilevered beams are considered instead of perimeter beams. The model could be further optimised by removing short cantilevering beams and adding additional columns. This was not done however to adhere to the brief and retain the footprint. It is important to note the beam pattern is not applied on the ground floor level.

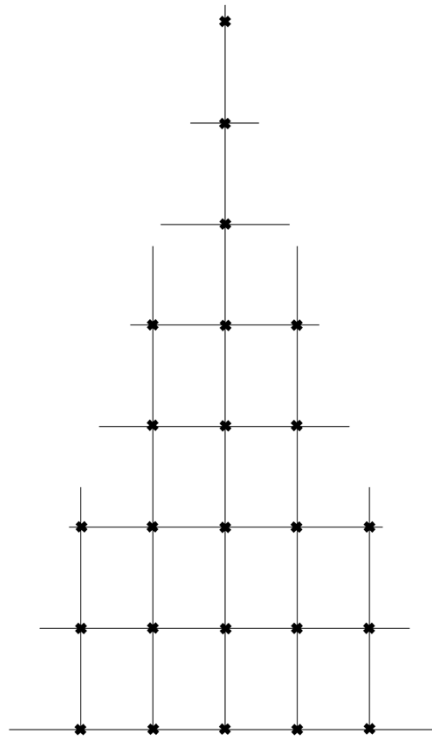

*Figure 3 – Squared beam pattern*

### **2.1. Initial hand checks**

Hand checks were performed for primary sizing of beams and columns using the following constants (*Table 1*).

*Table 1- Constants used*

	<i>Value</i>
Self-weight [kN]	0.36
Young's modulus [MPa]	210,000,000
Safety factor live load	1.5
Safety factor dead load	1.35

### 2.1.1. Beams

The members were sized based on the longest spanning beams, which serve as the primary beams. The specific bay arrangement including load distribution is shown in *Figure 4*.

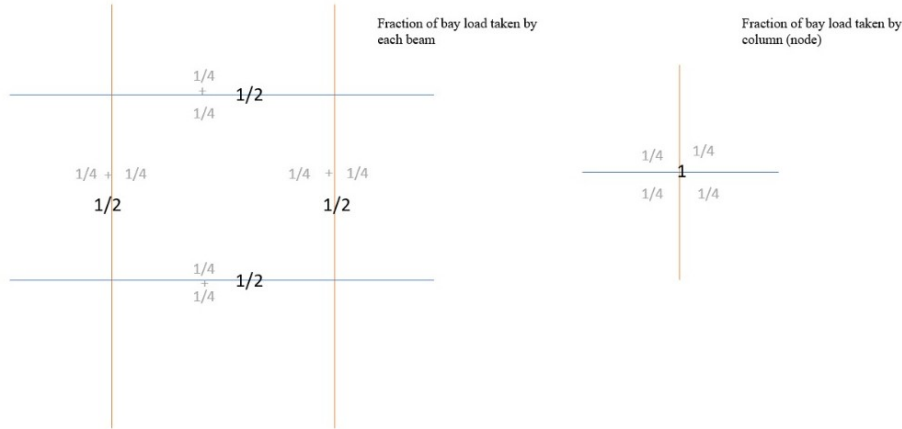

*Figure 4 - Specific Bay arrangement including load distribution*

The following equations were used to identify the loads on the beams:

The total load on the frame as stated in the brief is:

$$total\ load\ \left[\frac{kN}{m^2}\right] = 1.0 * DL + 1.5 * LL \quad E.1.$$

Where:

*DL*            Dead load [kN]  
*LL*            Live load [kN]

The load on a single bay is:

$$load\ on\ single\ bay\ [kN] = total\ load * bay\ area \quad E.2.$$

The load on a primary beam is:

$$load\ on\ primary\ beam\ [kN] = load\ on\ single\ bay * \frac{1}{2} \quad E.3.$$

The following equations were used to size the beams:

The max desired deflection,  $\sigma_{max}$  is:

$$\sigma_{max} = \frac{L}{200} \quad E.4.$$

Where:

$L$  Length of beam [m]

Using the maximum moment of inertia both the uniformly distributed load (UDL) and point load cases were calculated, the one with greatest moment of inertia was used for sizing.

The moment of inertia for a point load,  $I_{point}$  is:

$$I_{point} = \frac{FL^3}{48E\sigma_{max}} \quad E.5.$$

Where:

$F$  Point load [kN]  
 $E$  Young's modulus [MPa]

The moment of inertia for a uniformly distributed load,  $I_{UDL}$  is:

$$I_{UDL} = \frac{5wL^4}{384E\sigma_{max}} \quad E.6.$$

Where  $w$ , is UDL:

$$w \left[ \frac{kN}{m} \right] = \frac{F}{L} \quad E.7.$$

It was found that the point load had the greatest moment of inertia therefore, this was taken as the value to size for.

### 2.1.2. Columns

The columns were sized according to the axial compression force on the ground floor columns.

$$Load \ per \ column = DL + LL + BL \quad E.8.$$

The beam load, BL was calculated:

$$BL[kN] = perimeter \ of \ the \ bay[m] * unit \ weight \ of \ beam \left[ \frac{kN}{m} \right]$$

It is assumed that the unit weight of the beam is 0.36kN/m.

### 2.1.3. Results

The results found are summarised in *Table 2*, whereas the final 3D model is shown in *Figure 5*.

*Table 2 - Results (different permutations of grid size, inertia value, axial compression and size of columns and beam)*

	5 x 6	5 x 7	5 x 8
Moment of inertia internal beams (cm <sup>4</sup> )	12375	19651	29333
Moment of inertia external beams (cm <sup>4</sup> )	-	-	-
Axial compression of columns (kN)	1418	1651	1885
Columns	UC 203 X 203 X 52	UC 356 x 406 x 551	UC 203 X 203 X 71
Beams	UB 356X171X51	UB 406 X 178 X 60	UB 457 X 191 X 67

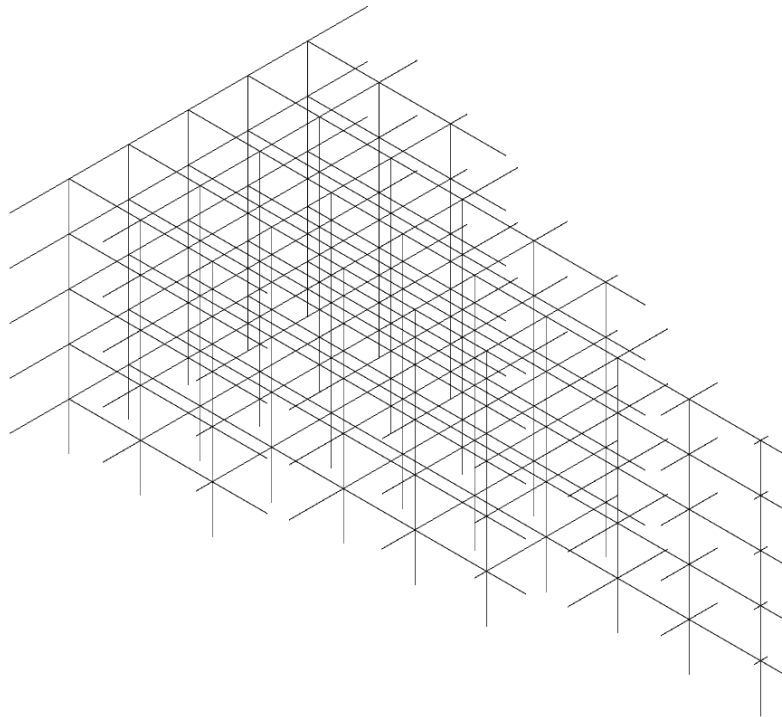

*Figure 5 - 3D model of frame*



### 3. TRIANGULAR FRAME

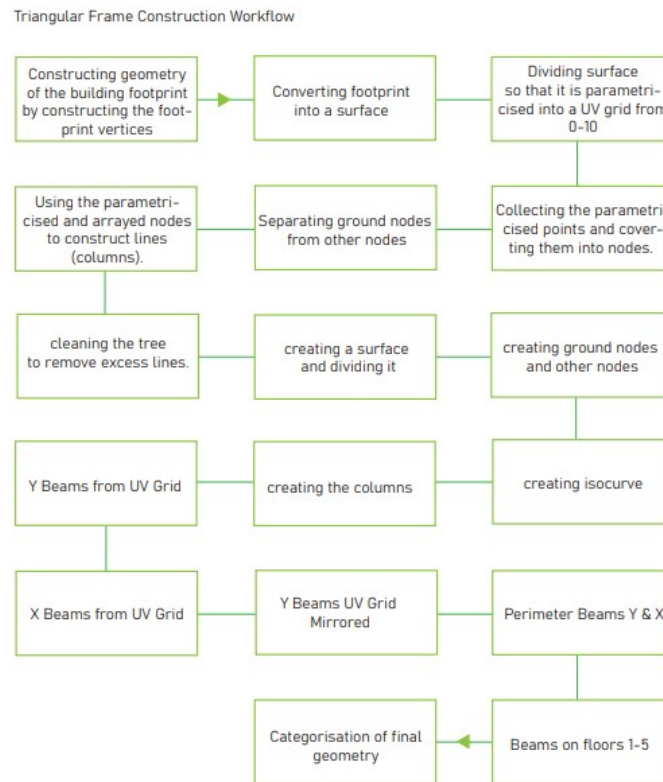

Figure 6 - Triangular grid workflow

A triangular beam patterned frame (Figure 7) was made using Grasshopper (Figure 6). The full script is found in Appendix 2. To create the frame a triangular grid which was trimmed by UV grid of the footprint. This did not result in cantilevered beams unlike the squared frame because the triangular beam structure was adjusted to fit within the footprint.

Using the same method as in section 2, the squared frame nodes were identified, beam pattern was arrayed for all stories and columns were made according to node positions. It is important to note the beam pattern is not applied on the ground floor level.

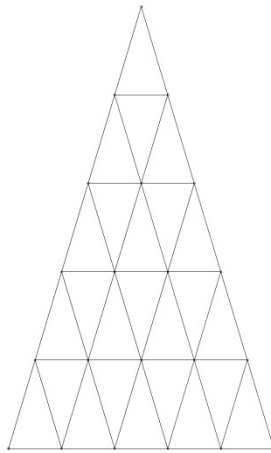

Figure 7 – Triangular beam pattern

### 3.1. Initial hand checks

Hand checks for primary sizing of beams and columns was performed using the same method described in section 2.1, the constants in *Table 1* were also used. However, instead of using the longest beam for sizing, the longest side of each isosceles triangle was used. Additionally, as all beams are considered load bearing as the triangular shape causes for load distribution in all directions, all beams were considered primary beams. This being said, the beams were categorised as internal or external beams.

The load on the internal and external beams were calculated as follows:

$$\text{load on internal beams [kN]} = \text{load on single bay} * \frac{2}{3} \quad \text{E.9.}$$

$$\text{load on perimeter beams [kN]} = \text{load on single bay} * \frac{1}{3} \quad \text{E.10.}$$

The specific bay arrangement including load distribution is shown in *Figure 8*.

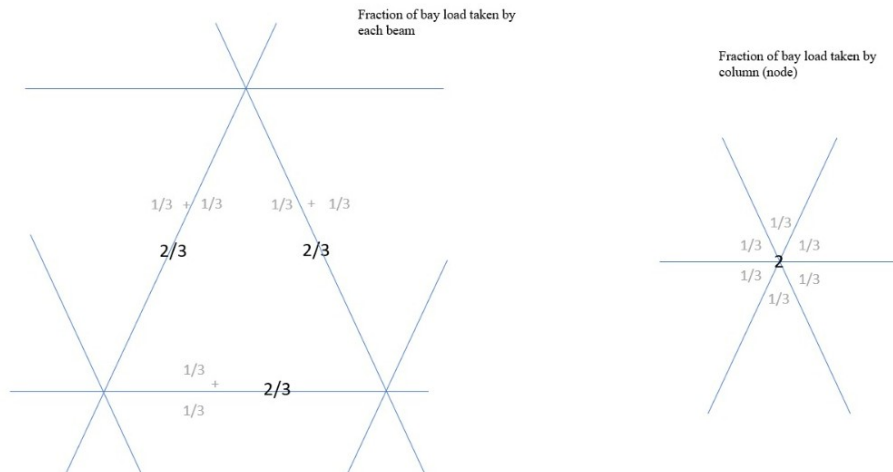

*Figure 8 - Specific Bay arrangement including load distribution*

It is important to note that each column supports six bays instead of four in the case of the squared frame.

### **3.1.1. Results**

The results found are summarised in *Table 3*, whereas the final 3D model is shown in *Figure 9*. The external beams were sized according to the internal beams as worst-case scenario was considered.

*Table 3 - Results*

	<i>Value</i>
Moment of inertia internal beams	24092.56 cm <sup>4</sup>
Moment of inertia external beams	12046.28 cm <sup>4</sup>
Axial compression of columns	1989.51 kN
Columns	UC 203 x 203 x 71
Beams	CB 406 x 178 x 67

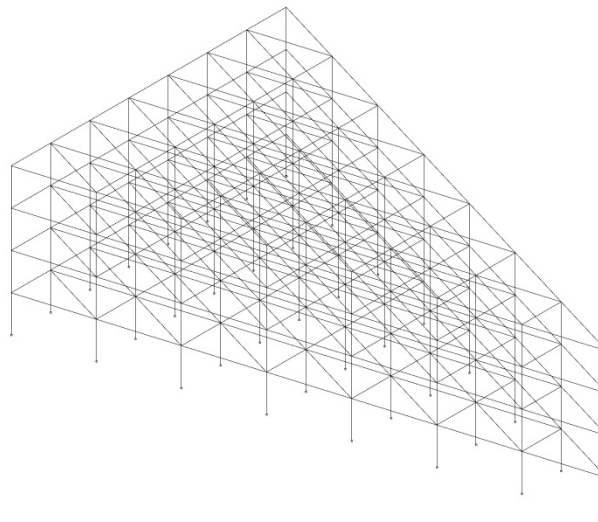

*Figure 9 - 3D model of frame*

#### 4. RHOMBOID FRAME

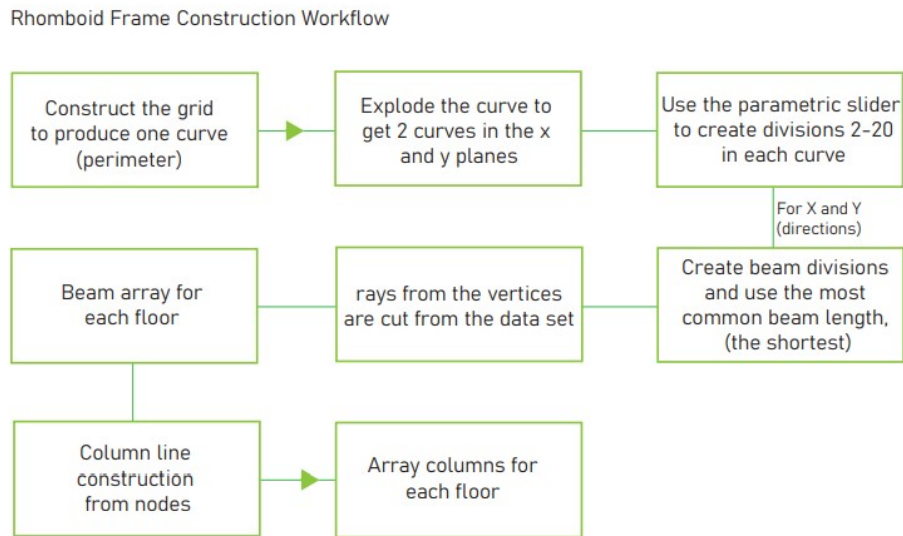

Figure 10 - Rhomboid grid workflow

A rhomboid beam patterned frame (Figure 11) was made using Grasshopper (Figure 10). The full script is found in Appendix 3. To create the frame the coordinates of the vertices of the footprint were used to create two curves resulting in one side not having perimeter beams, but this counter measured by mirroring the other perimeter beams. This was done so that the script was able to interrupt the footprint as a quadratic shape, resulting in a side having triangular bays.

Using the same method as in section 2, the rhomboid frame nodes were identified, beam pattern was arrayed for all stories and columns were made according to node positions. It is important to note the beam pattern is not applied on the ground floor level.

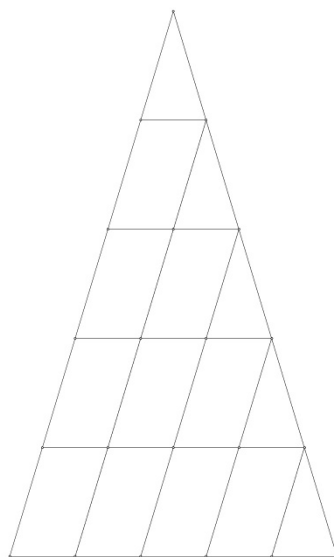
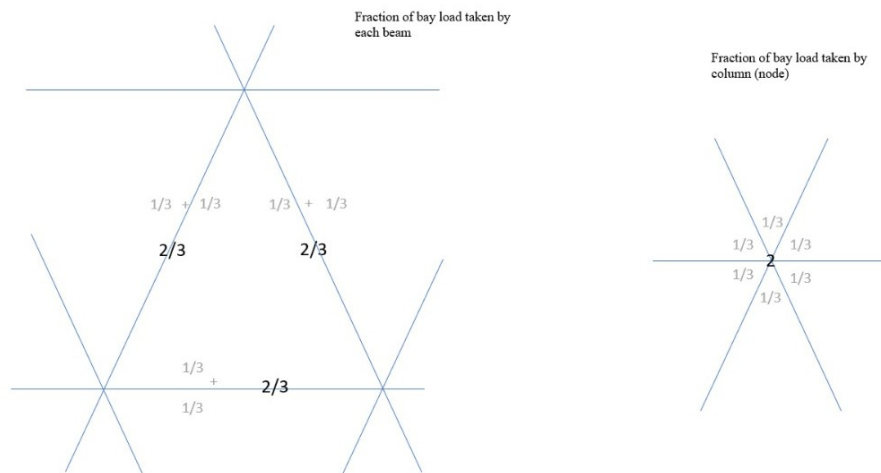

Figure 11 - Rhomboid beam pattern

#### 4.1. Initial hand checks

Hand checks for primary sizing of beams and columns were performed using the same method as in section 2.1 by taking the longest member and designing for it, the constants in *Table 1* were also used. The specific bay arrangement including load distribution is shown in *Figure 12*.



*Figure 12- Specific Bay arrangement including load distribution*

##### 4.1.1. Results

The results found are summarised in *Table 4*, whereas the final 3D model is shown in *Figure 13*. The external beams were sized according to the internal beams as worst-case scenario was considered and they are most common within the structure.

*Table 4 - Results*

	<i>Value</i>
Moment of inertia internal beams	78237.05 cm <sup>4</sup>
Axial compression of columns	2941.40 kN
Columns	UC 305 x 305 x 97
Beams	UB 610 x 229 x 113

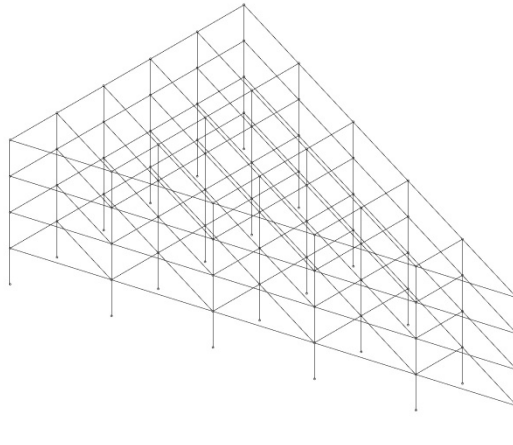

*Figure 13 - 3D model of frame*

## 5. BHoM ANALYSIS

Properties were assigned to the nodes, beams and columns using *BHoM* commands in Grasshopper. For all frame patterns the same script was used, *Appendix 3.4*.

Ground nodes were identified, and fixed constraints were assigned. Using the sizing conducted in previous sections, UB and UC sections for S275 were assigned to lines representing the beams and columns (bars).

For the squared frame, X (primary beams) and Y (secondary beams) beams were assigned the same sections because primary and secondary beams were assumed the same for the first permutation. For the triangular and rhomboid frame internal beams and perimeter beams were assigned the same sections because primary and secondary beams were assumed the same for first permutation.

Load cases were the identified for self-weight (SW), dead load (DL) and live load (LL). For the squared frame primary X beams were “pulled” from the BHoM model and assigned a DL and LL case because the load is applied on beams in only one direction. For the triangular and rhomboid frame all beams were “pulled” from the BHoM model and assigned a DL and LL case because the load was distributed on all beams. With regards to SW, all bars were pulled and designed.

Load combinations were assigned using the given equation:

$$1.0 * SW + 1.0 * DL + 1.5LL \quad E.11.$$

Additionally, a script “pulling” the total building weight was added to all grid variations by using the reactions at supports in the SW load case, adding them and transforming kN in kg.

## 6. ROBOT ANALYSIS

The three grasshopper scripts with rectangular, triangular, and rhomboid grids were structurally tested in Autodesk Robot. Using a Robot adapter component the BHoM scripts were sent (or *pushed*) to Robot for analysis. For each grid type, three element sizes are chosen. Each of the final 9 scripts was first analysed with the hand sized beams and columns, which were then changed based on stress checks.

For the building to pass checks the following values were considered: for beams a maximum stress of 275MPa ( $\sigma_{max} = f_y$ ) and, for columns a compressive axial stress of maximum 137.5MPa ( $\sigma_{max} = 0.5f_y$ ). To make the building as efficient and optimised as possible elements with stresses under  $0.5\sigma_{max}$  were considered oversized. Several iterations were analysed for each of the 9 scripts to achieve the two condition stresses  $> 0.5\sigma_{max}$  and  $< \sigma_{max}$  for all elements.

Elements were checked in groups instead of simply beams and columns to allow for more specific adjustments to sizes of elements based on load distribution. Columns were grouped by floor (1 through 5 for each of the 9 scripts), beams are grouped either by support type (simple/cantilever) or by direction (x and y). Groups could have been smaller for additional optimisation; however, having too many different cross section elements would make construction complicated and more costly. Therefore, this was not modelled.

The overall weight of the building frame was used as a factor to compare all valid permutations as it represents both element density and size (it shows the overall amount of steel used).

### 6.1. Rectangular frame

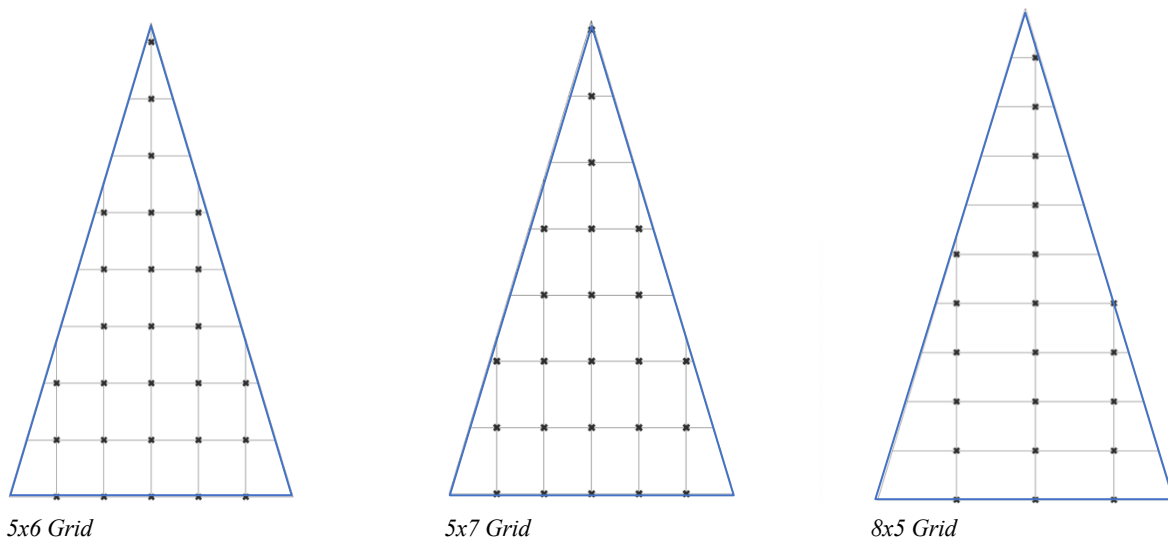
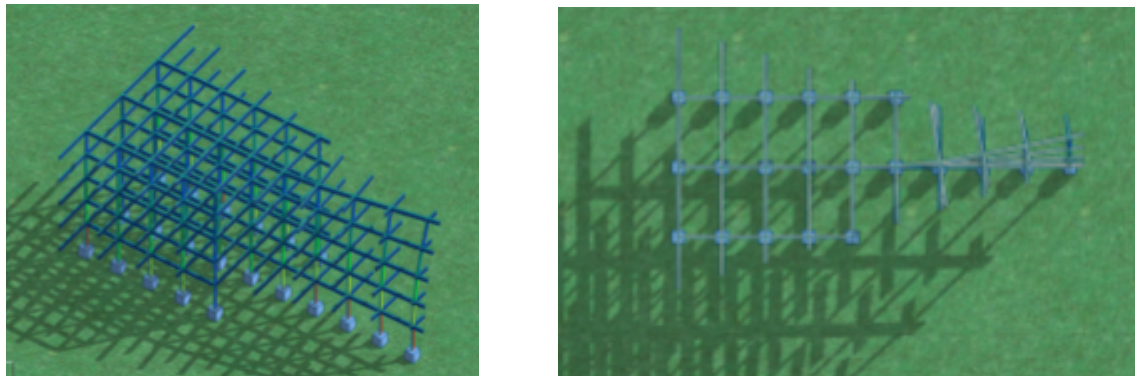

Figure 14 – Permutations rectangular frame (footprint outlined in blue)

For the rectangular frame three possible permutations were chosen: 5x6; 5x7 and 8x5 (Figure 14); these are diverse in output while still achieving the footprint (some sizes like 6x7 cause floating beams). Each of the three was analysed in Robot with multiple iterations until passing

all checks. Columns were divided by floor, while beams were categorised as internal and cantilevered.

The 5x6 grid performs well. The 5x7 grid passes all checks, but with a load higher than the 5x6. The 8x5 grid being unsymmetrical causes the building to tilt to one side with extreme stresses, leading to unpassed checks (see *Figure 15*). This could be solved with supporting columns. *Table 5* shows the final iteration sizing and load for each of the three permutations.



*Figure 15 - 8x5 grid failing, deflecting to one side*

*Table 5 – Final permutations of squared frame (stresses shown in green pass checks, stresses in red do not)*

	5x6		5x7		8x5	
<i>Columns floor 1</i>	UC 254x254x107	120.1 6	UC 254x254x167	90.27	UC 254X254X167	105.4 9
<i>Columns floor 2</i>	UC 254x254x107	96.1	UC 254x254x132	91.47	UC 254X254X132	106.9 7
<i>Columns floor 3</i>	UC 203x203x60	128.1 8	UC 203x203x86	104.6 8	UC 203x203x86	122.4 7
<i>Columns floor 4</i>	UC 203x203x46	111.2 1	UC203x203x60	100.4 4	UC 203x203x86	81.63
<i>Columns floor 5</i>	UC 152x152x23	111.7 4	UC 152x152x37	81.44	UC 203x203x46	76.34
<i>Cantilevers</i>	UB 457x191x89	228.6 1	UB 533x210x122	169.8 1	UB 610x305x149	215.6 8
<i>Beams internal</i>	UB 457x191x89	213.5 1	UB 457x191x82	262.4 1	UB 838x292x176	439.4 8
<i>Total weight</i>	147050.00		168399.00		255547.00	



## 6.2. Triangular frame

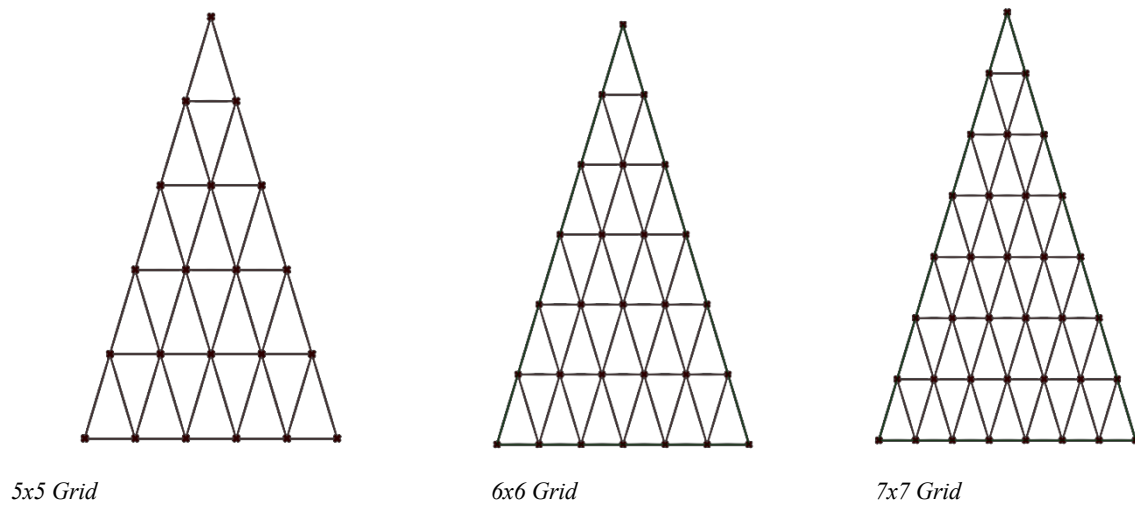

Figure 14 – Permutations triangular frame

For the triangular frame the chosen grids were 5x5, 6x6 and 7x7. Columns were grouped by floor and beams by internal (full load) and perimeter (half load). All three permutations passed the checks. The least dense grid (5x5) performs best (with a load of 277371kg), despite requiring members of bigger cross section, which might be less cost effective. Final iterations for each permutation are shown in *Table 6*. To further optimise this pattern smaller grid sizes could be analysed, with a better understanding of load distribution on beams.

Table 6 – Final permutations of triangular frame (stresses shown in green pass checks)

	5x5		6x6		7x7	
<i>Columns floor 1</i>	UC 356x406x287	129.1 7	UC 356x406x287	97.23	UC 356x406x287	77.66
<i>Columns floor 2</i>	UC 356x406x287	97.59	UC 356x406x287	73.54	UC 356x406x177	94.75
<i>Columns floor 3</i>	UC 356x406x235	81.53	UC 356x368x177	81.17	UC 356x368x129	88.68
<i>Columns floor 4 and 5</i>	UC 203x203x86	115.2 5	UC 203x203x86	86.44	UC 203x203x71	98.34
<i>Internal beams</i>	UB 457x191x133	173.4 9	UB 457x191x98	152.7 4	UB 457x191x98	100.1 7
<i>External Beams</i>	UB 457x191x133	144.4 7	UB 457x191x98	123.8 8	UB 457x191x98	83.36
<i>Total weight</i>	277371.36		278540.20		305113.25	

### 6.3. Rhomboid frame

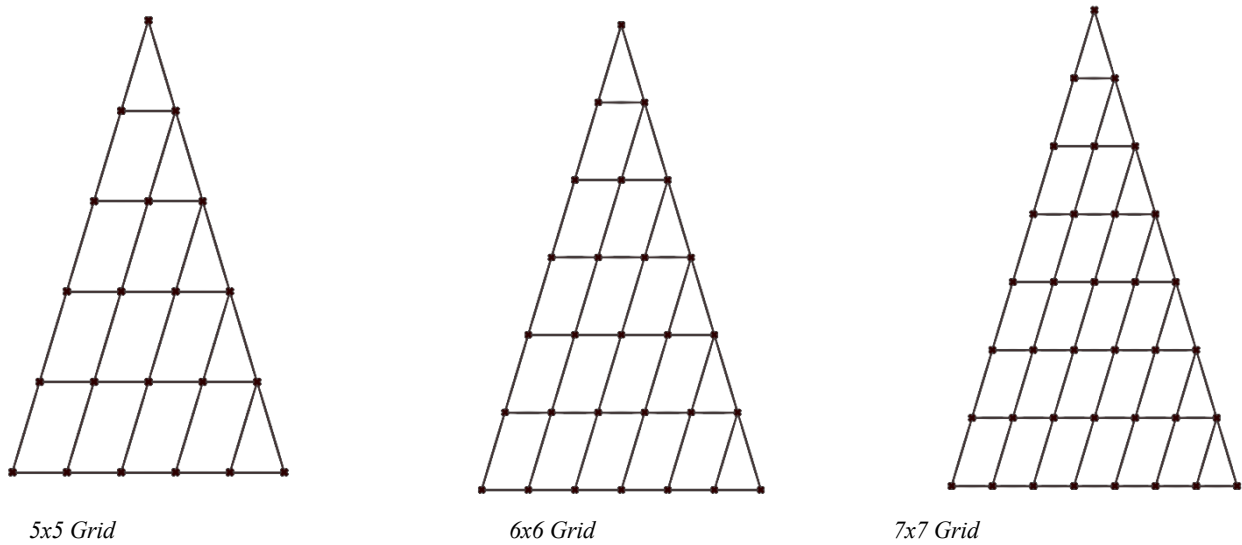

Figure 15 – Permutations rhomboid frame

For the rhomboid frame, grid sizes of 5x5, 6x6 and 7x7 were tested, *Figure 15*. Columns were grouped by floor, whereas beams by direction (x and y beams). All permutations pass the checks with the 7x7 grid performing best (weight of 183735kg), seen in *Table 7*.

Table 7 – Final permutations of rhomboid frame (stresses shown in green pass checks)

	5x5		6x6		7x7	
<i>Columns floor 1</i>	UC 356x406x287	137.3 2	UC 305x305x240	120.0 7	UC 305x305x198	113.1 5
<i>Columns floor 2</i>	UC 305x305x283	112.5 1	UC 305x305x198	117.3 6	UC 305x305x137	131.7 8
<i>Columns floor 3</i>	UC 305x305x240	100.5 7	UC 305x305x137	128.8 2	UC 305x305x118	115.9 4
<i>Columns floor 4</i>	UC 305x305x118	136.6 1	UC 305x305x97	123.9	UC 254x254x73	126.7 9
<i>Columns floor 5</i>	UC 203x203x86	98.11	UC 203x203x52	119.1 9	UC 203x203x52	91.59
<i>Beams x</i>	UB 457x191x82	151.8 9	UB 356x127x39	251.3 9	UB 305x127x37	201.0 2
<i>Beams y</i>	UB 610x229x113	240.7 4	UB 457x152x82	270.4 8	UB 406x178x60	262.7
<i>Total weight</i>	239954.00		198339.00		183735.00	

#### ***6.4. Comparison***

For each of the three grid shapes the respective optimised structures are: rectangular 5x6; triangular 5x5; rhomboid 7x7. The best performing permutations out of these is the rectangular 5x6 with a self-load of 147050kg. The rectangular grid has no perimeter beams or columns lowering the number of elements. While this means it requires larger cross sections, the reduced elements still result in a much lower final weight of the building. The rhomboid and triangular grids are analysed with more conservative assumptions with regards to load distribution, making optimisation harder to achieve. However, this is negligible as the difference in weight is over 40 tons.

#### **7. CONCLUSION**

Given the 9 possible permutations analysed, the optimal frame for the given footprint is the rectangular 5x6 grid with a total weight of 147050kg. For further optimisation it would be of interest to test more grid sizes and potentially add supporting columns to some cantilevering beams in the final model.

# APPENDICES

## 1. RECTANGULAR FRAME

### 1.1. Footprint and gridlines

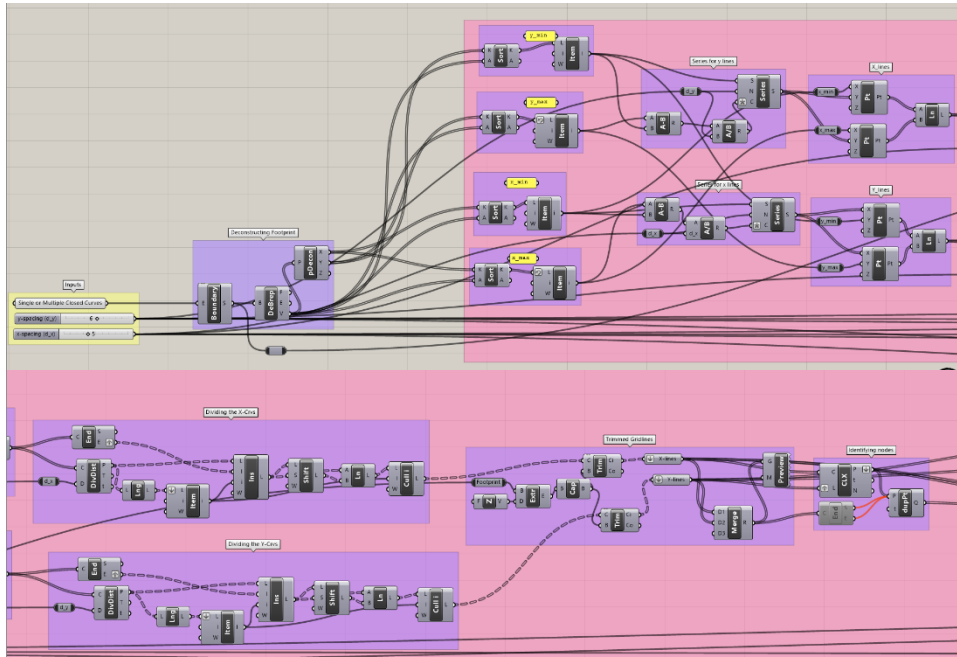

### 1.2. Columns and Beams

#### 1.2.1. Beams

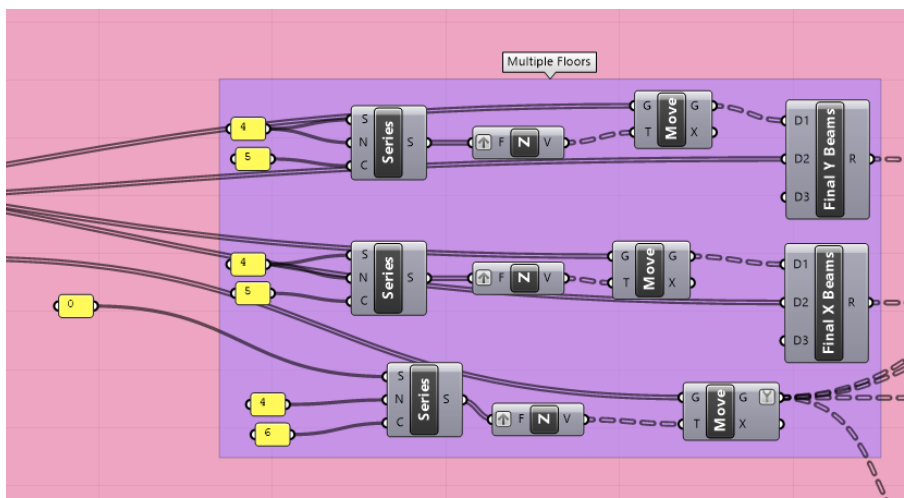

### 1.2.2. Columns

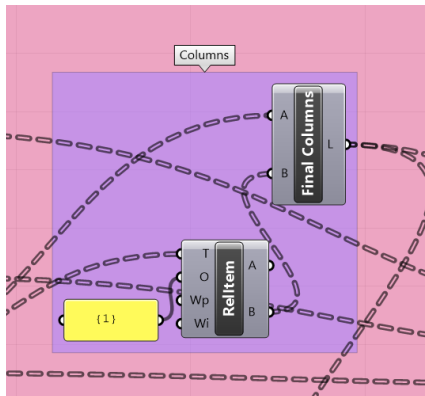

### 1.3. Sizing

#### 1.3.1. Preliminary beam sizing

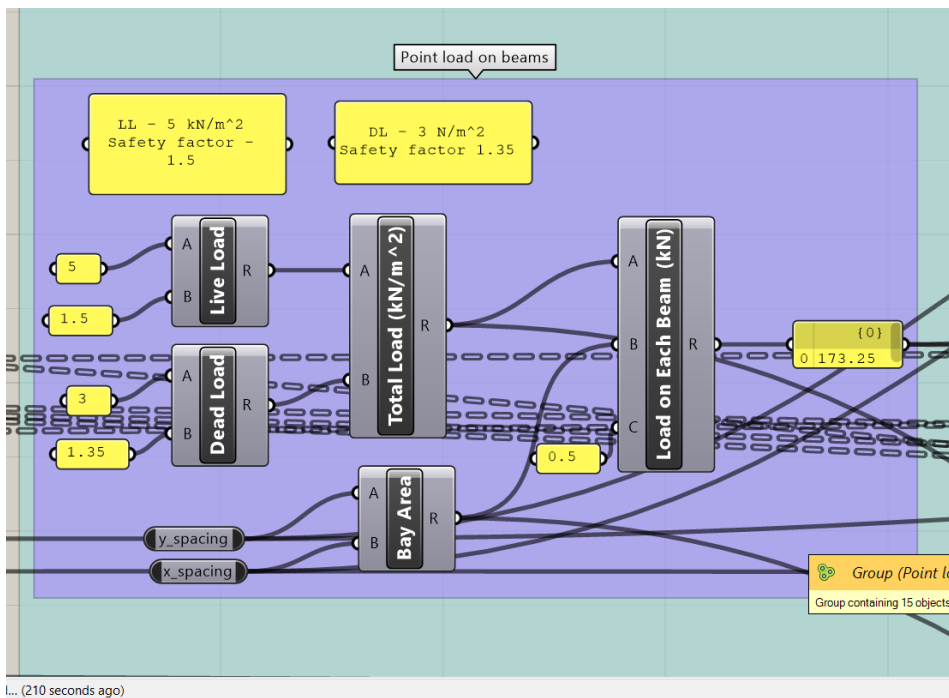

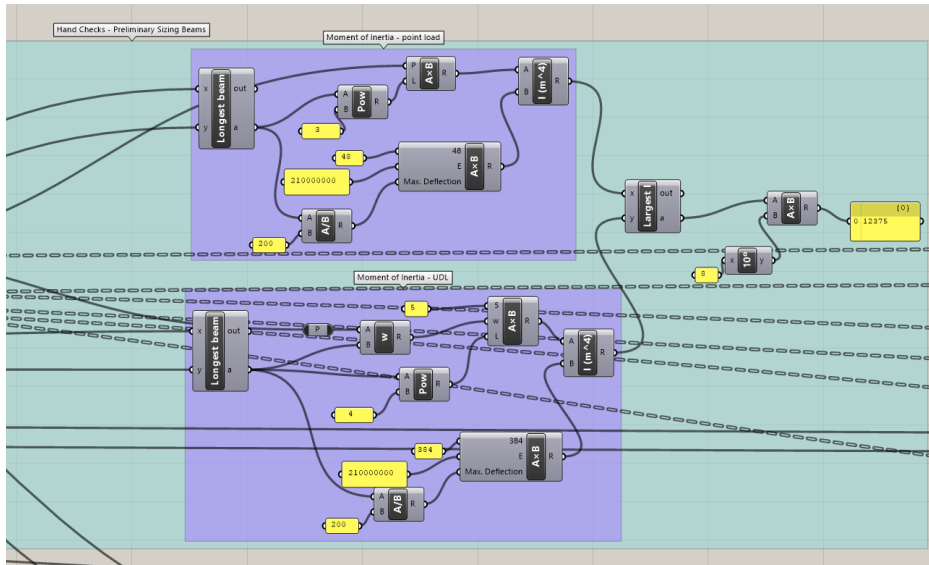

### 1.3.2. Preliminary column sizing

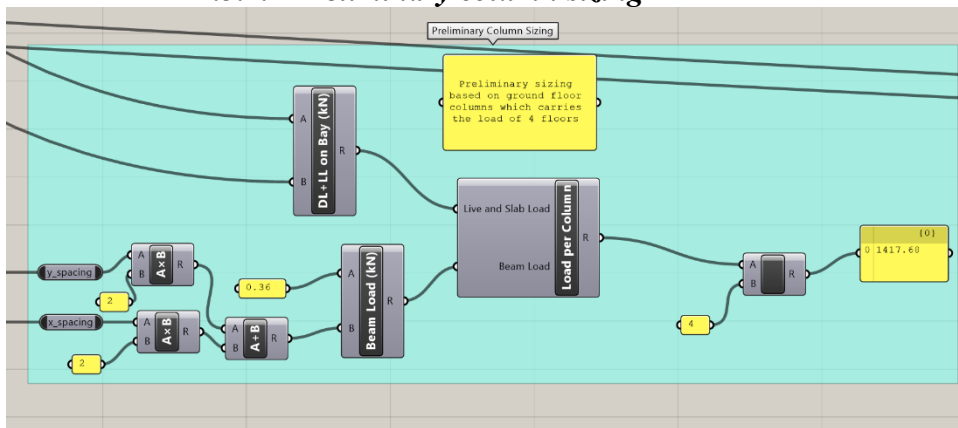

## 2. TRIANGULAR FRAME

### 2.1. Footprint and gridlines

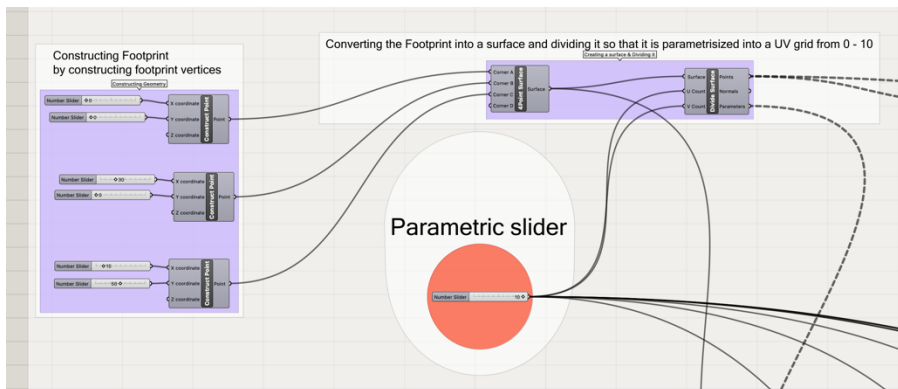

## 2.2. Columns and Beams

### 2.2.1. Beams

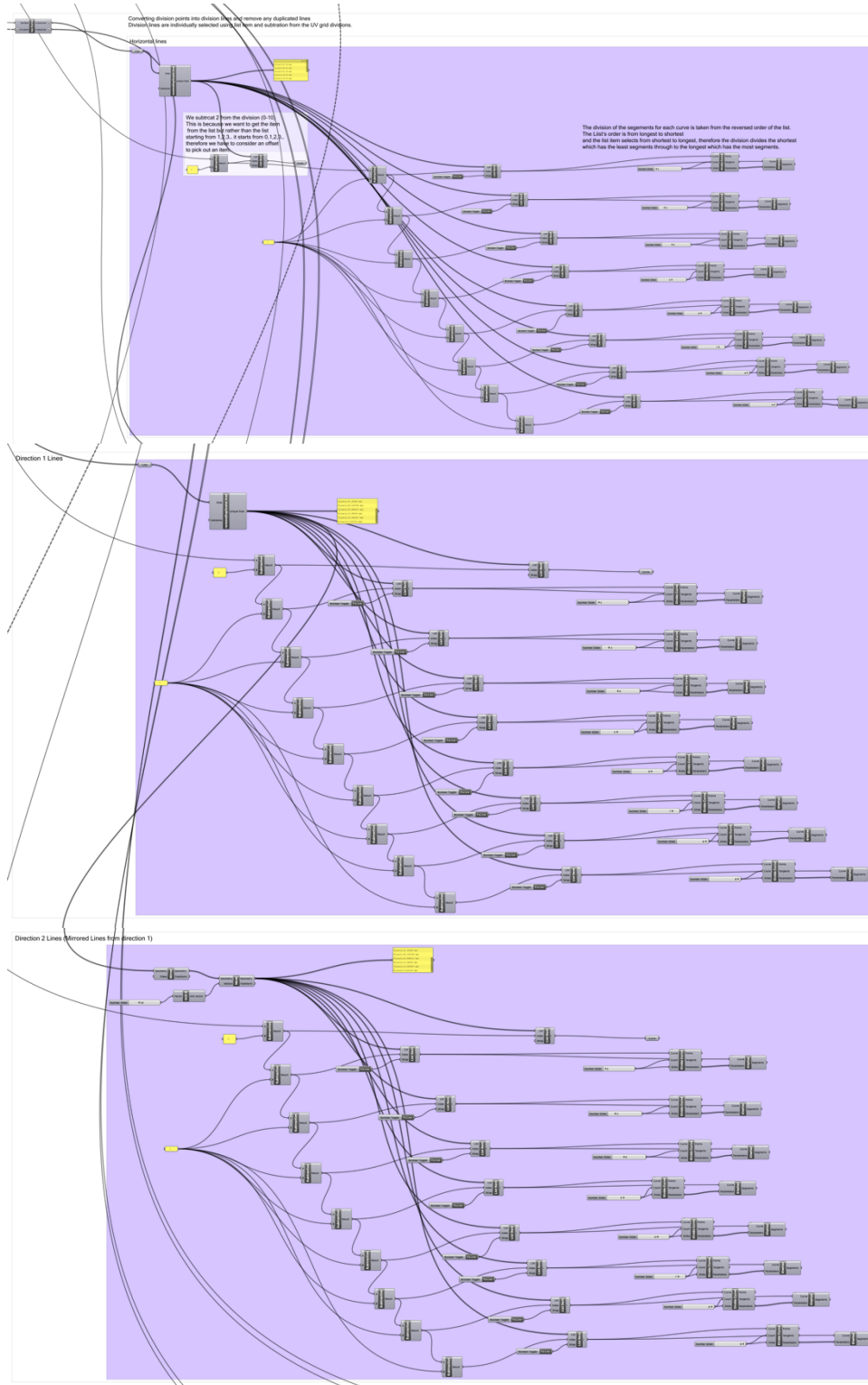

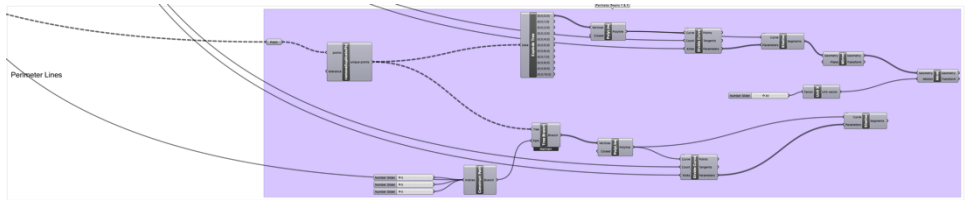

Array for each beam at each level

Beams Array in the X Direction - No. Floors and floor height

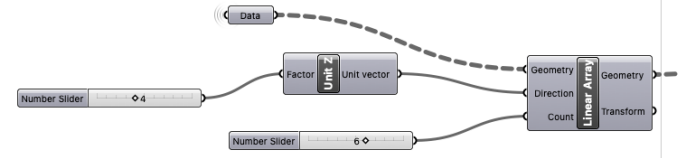

Beams Array in the Y Direction - No. Floors and floor height

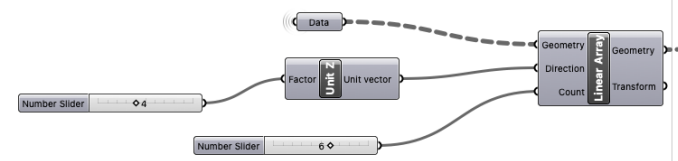

Beams Array on the Perimeter - No. Floors and floor height

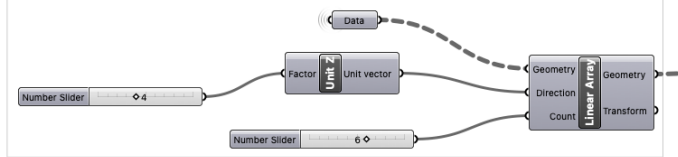

### 2.2.2. Columns

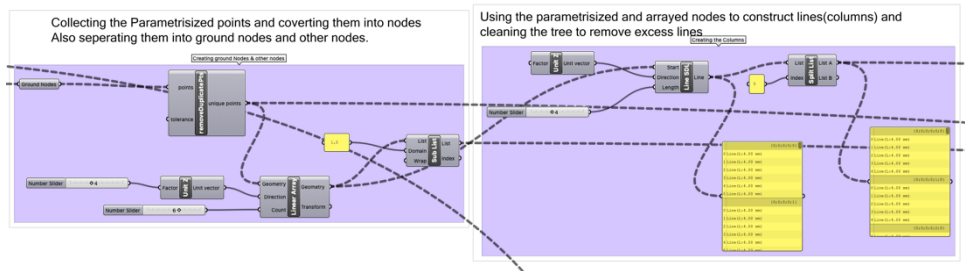

### 2.3. Sizing

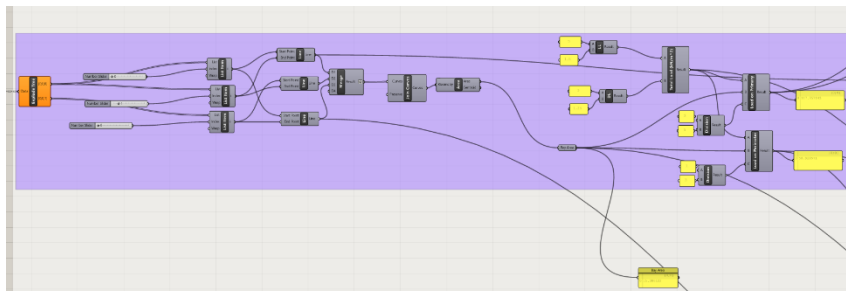



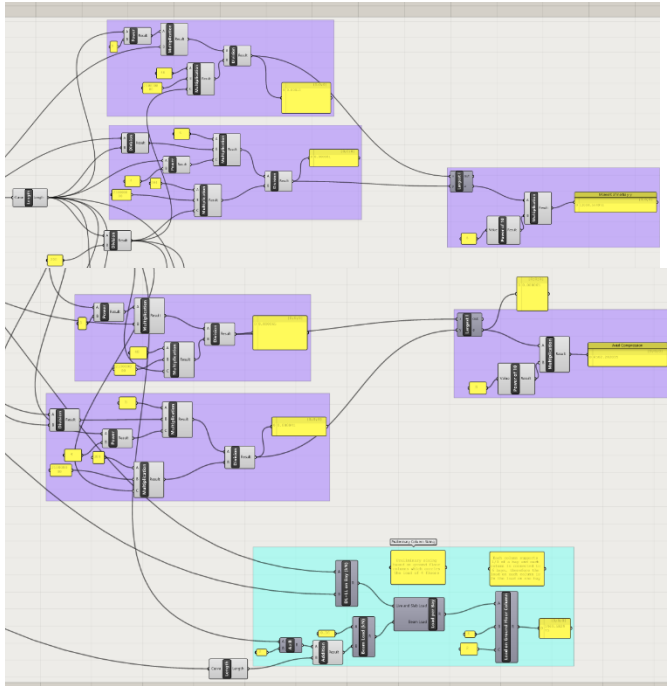

### 3. RHOMBOID FRAME

#### 3.1. Footprint and gridlines

Building footprint construction

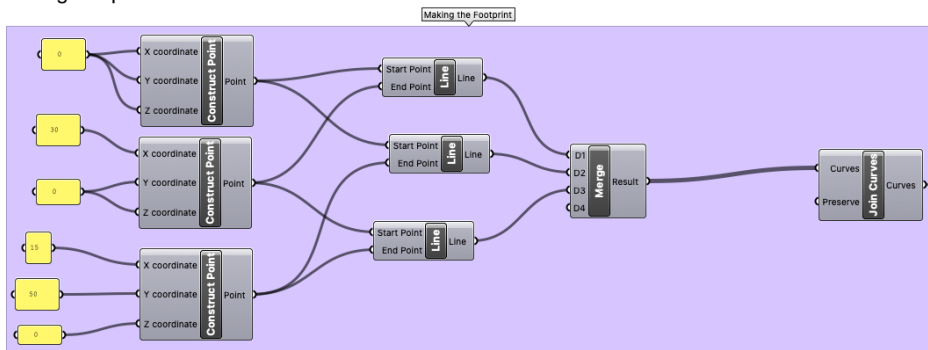

Explode the curves and get 2 curves  
Use the parametric slider to create divisions, 2-20

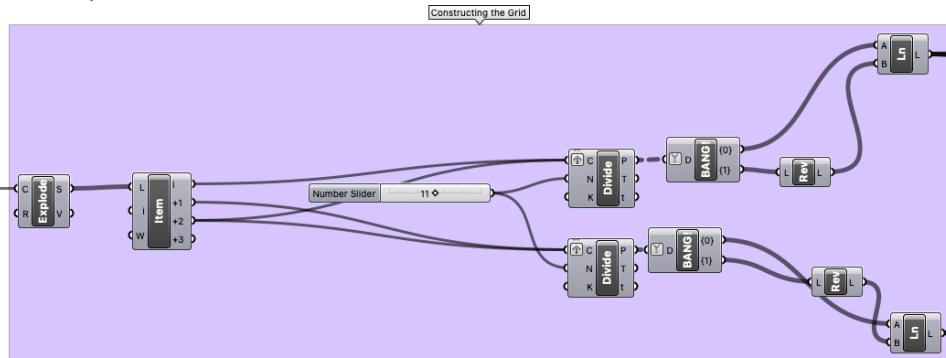



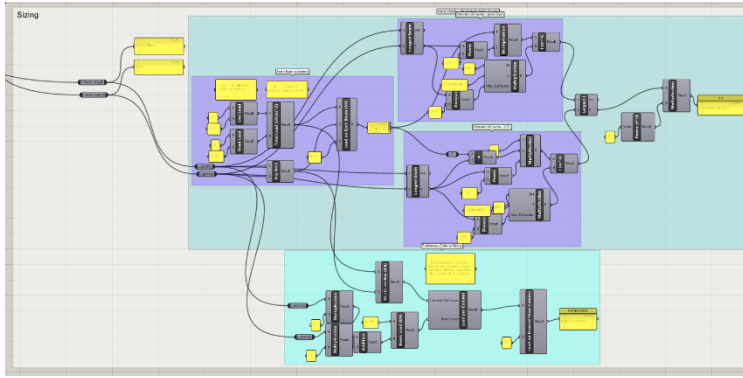

### 3.4. BHoM computation

#### 3.4.1. Assigning properties

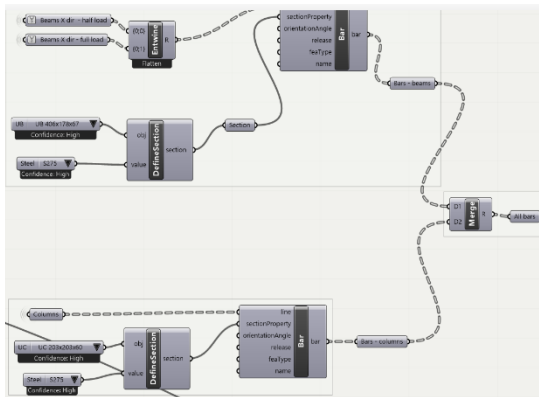
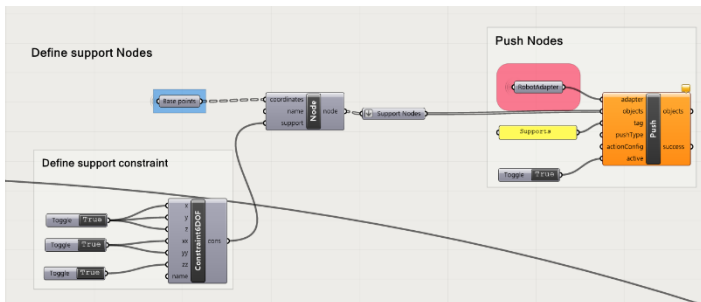

### 3.5. Loads

