

THE LAIR ON THE YARE

SARA MOTWANI UNIT 7

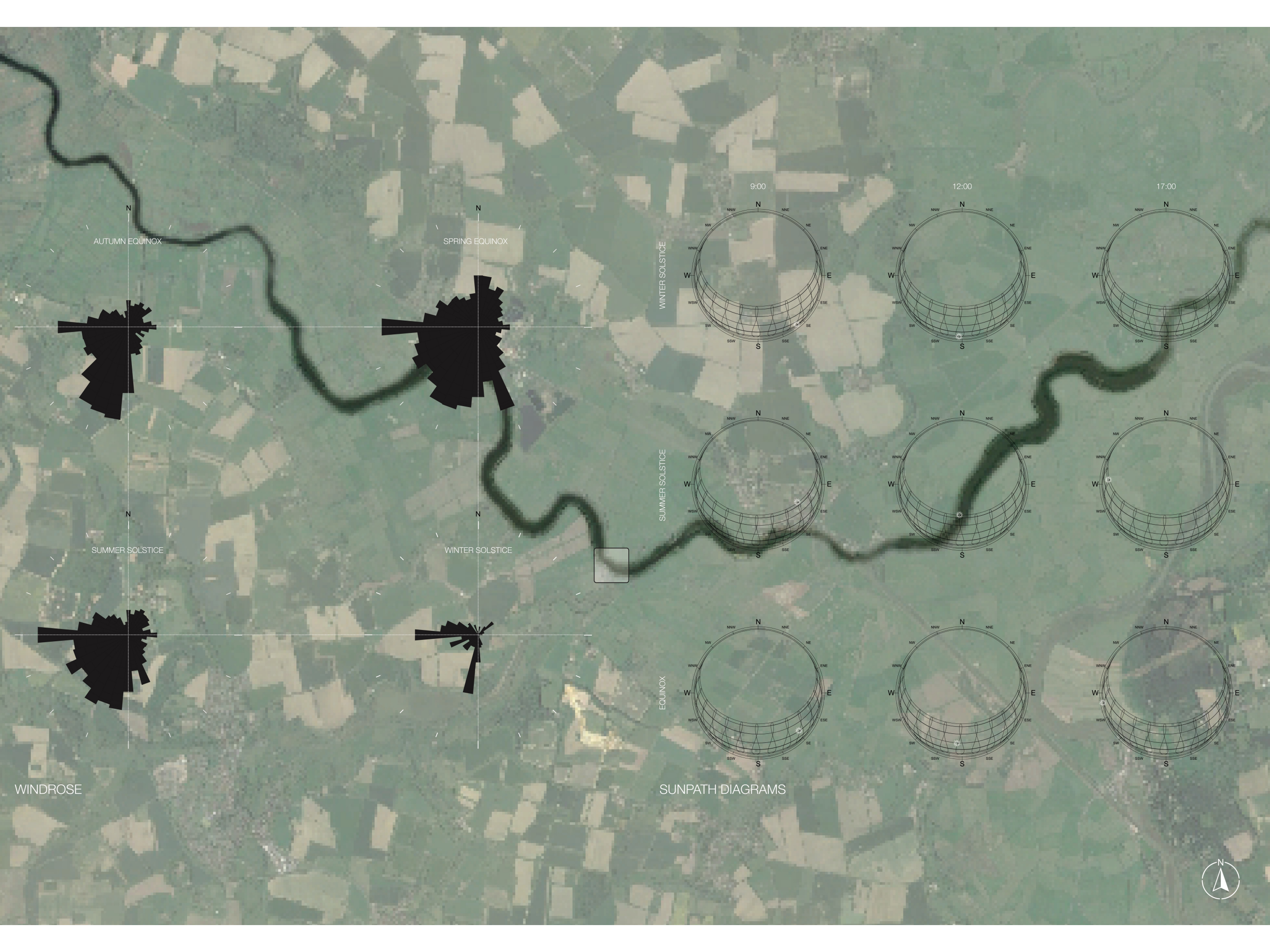

AUTUMN EQUINOX

SPRING EQUINOX

WINTER SOLSTICE

SUMMER SOLSTICE

EQUINOX

SUMMER SOLSTICE

WINTER SOLSTICE

SUNPATH DIAGRAMS

WINDROSE

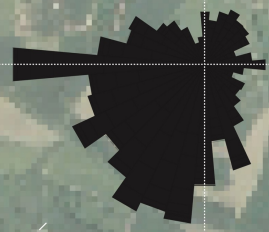
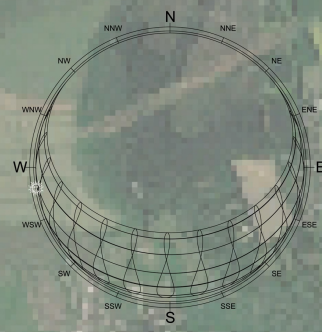
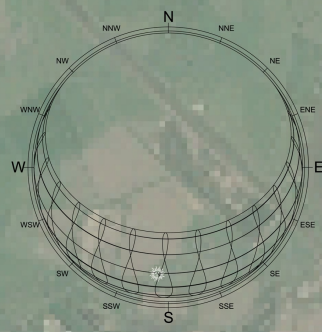
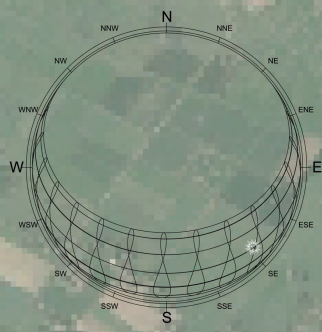
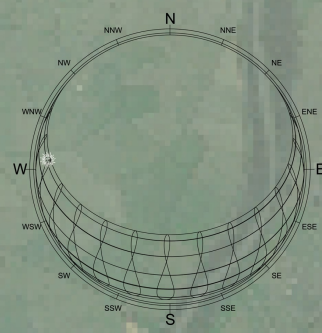
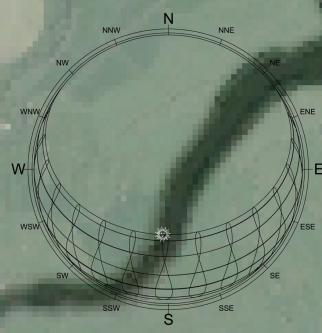
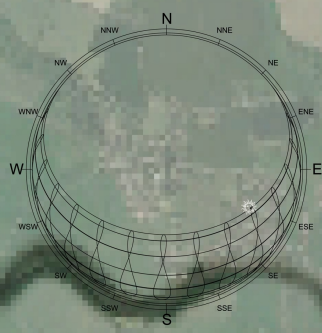
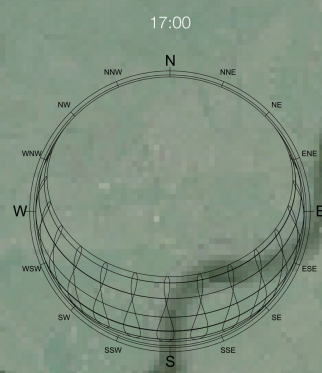
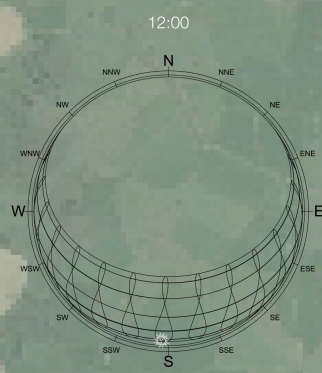
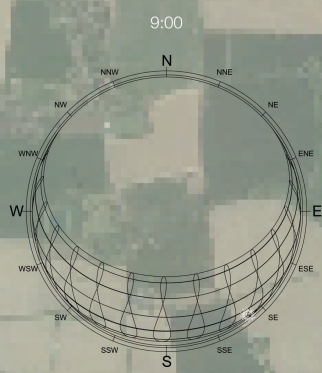
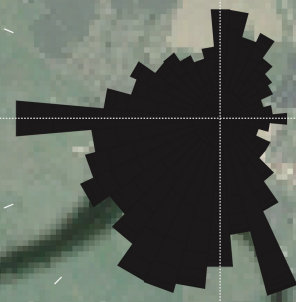



THE SPECIES

GREY SEALS HAVE THEIR BABIES AND NURSE THEM BY THE SHORE

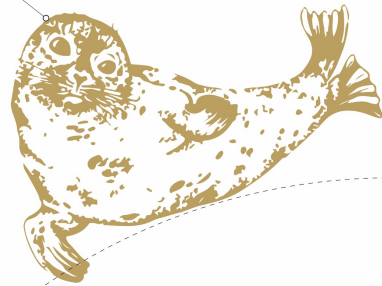

BRITAIN'S LARGEST BUTTERFLY, SWALLOWTAIL

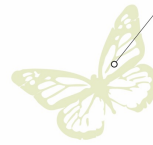

MARSH HARRIER

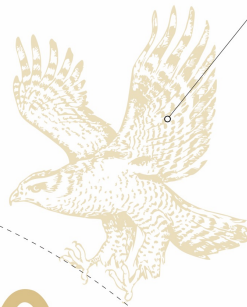

RARE WARBLERS

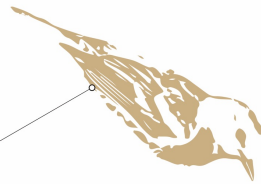

PURPLE SEA LAVENDER



MUSHROOMS AND TOAD STOOLS



SWALLOWTAIL



RED FLANKED BLUE TAILS

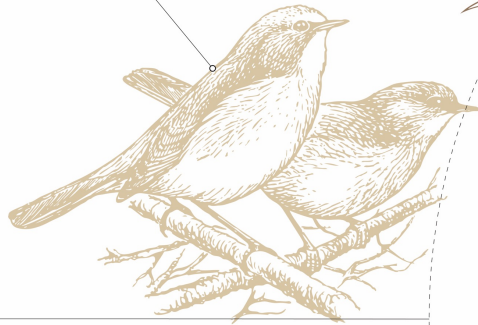

THE WHITE CLAWED, NATIVE CRAYFISH

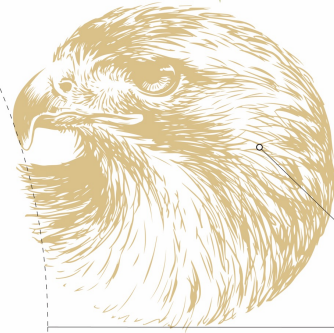

DARK BELLIED BRENT GOOSE



DAMSELFLIES, FLY CLOSE TO THE WATER SURFACE



WATERFOWL



ADDER, BRITAIN'S ONLY VENOMOUS SNAKE



CHINESE WATER DEER

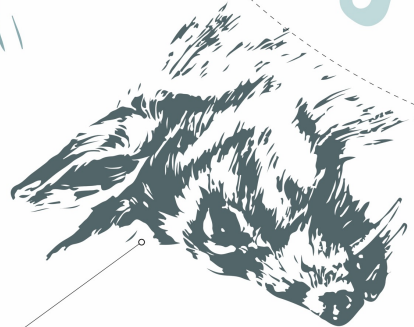

MIGRATING SWALLOWS



ELUSIVE HARBOUR PORPOISE

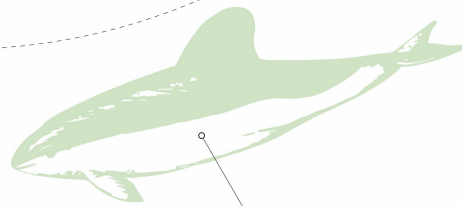

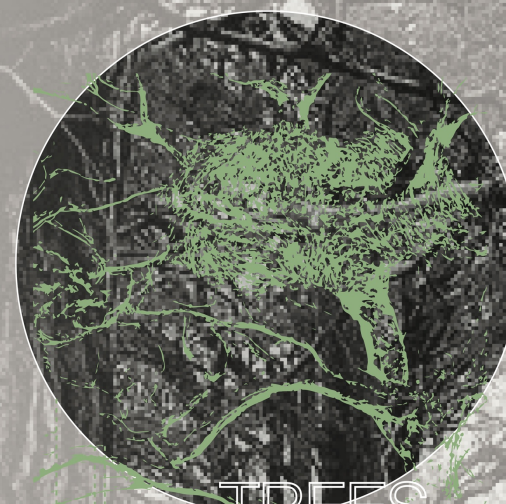
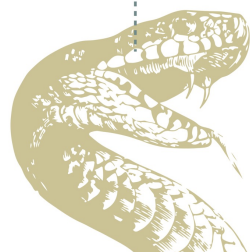
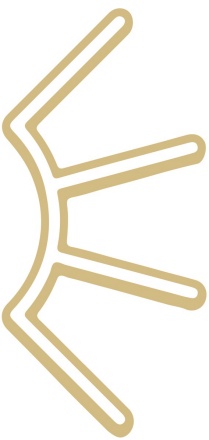

TREES

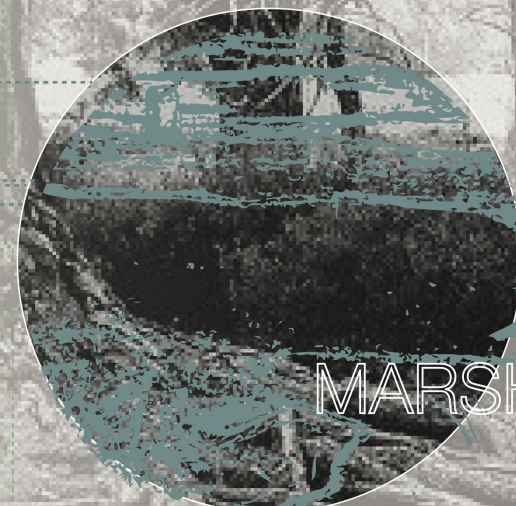

MARSHES



ROOTS

HABITATS

THE DRAGON

THE TALE OF THE LUDHAM DRAGON

IN 1782, THE QUIET VILLAGE OF LUDHAM FOUND ITSELF EMBROILED IN ONE OF THE **STRANGEST STORIES** IN NORFOLK FOLKLORE.

A HOLE APPEARED ON THE MAIN STREET, NEAR TO THE VILLAGE PUB WHICH UPON INVESTIGATION BY CURIOUS VILLAGERS, WAS FOUND TO

LEAD TO AN **UNDERGROUND MAZE OF TUNNELS** STRETCHING FAR BENEATH THE CHURCHYARD AND BEYOND. THESE

WERE NOT ORDINARY TUNNELS BUT HAD BEEN DUG BY A DRAGON THAT HAD MADE ITS LAIR BENEATH THE SLEEPY VILLAGE.

EVERYDAY THE VILLAGERS BLOCKED THE HOLE WITH RUBBLE BUT EVERY NIGHT THE DRAGON BROKE OUT TO TERRORISE THE VILLAGE, **SAVAGE LIVESTOCK** AND **CAUSE MAYHEM** SO NO ONE WOULD DARE LEAVE THEIR HOUSE AFTER DARK.

DESCRIBED AS A **SURPRISING REPTILE**, IT WAS SAID TO MEASURE A FULL **15 FEET LONG**, **WINGED SCALED** AND WITH A **FEARSOME MOUTH** FILLED WITH RAZOR-SHARP TEETH, RESEMBLING A DRAGON OR A MONSTROUS SERPENT. IT BECAME KNOWN AS THE **LUDHAM DRAGON**.

ONE BRIGHT SUNSHINY AFTERNOON, TO THE HORROR OF THE INHABITANTS, IT WAS SEEN TO LEAVE THE BURROW. AS SOON AS IT HAD GOT SOME DISTANCE AWAY, A **COURAGEOUS PARISHIONER** DROPPED A SINGLE LARGE ROUND STONE INTO THE MOUTH OF THE BURROW, COMPLETELY FILLING IT UP.

AFTER BASKING IN THE SUN FOR SOME TIME THE MONSTER RETURNED. NOT BEING ABLE TO REMOVE THE STONE IT TURNED AWAY **BELLOWING** AND **LASHING** ITS SIDES FURIOUSLY WITH ITS TAIL. IT THEN MADE ITS WAY ACROSS THE FIELDS IN THE DIRECTION OF THE BISHOP'S PALACE. TURNING TO THE LEFT IT MADE ITS WAY ALONG THE DREARY CAUSEWAY LEADING TO THE RUINED ST BENETS ABBEY GATEWAY. ROUND AND ROUND IT RAN, THROWING UP STONES AND DIRT IN ITS FURY AND RAISING ITS HIDEOUS FORM UP AGAINST THE RUINED WALLS, AT LAST IT ENTERED THE **GLOOMY ARCHWAY** WHERE IT IS SUPPOSED TO HAVE MADE ITS WAY TO THE VAULTS BENEATH AND WAS **NO MORE SEEN**.

THE SCALES AND THE WINGS

WERE ITS MAIN IDENTIFIERS THAT SERVE AS A VISUAL DESIGN INSPIRATION

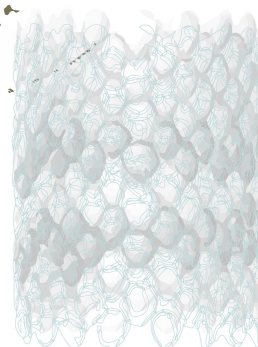

DRAGON WING STYLE 1

DRAGON WING STYLE 1

BIRD WING STUDIES

OPENED WING

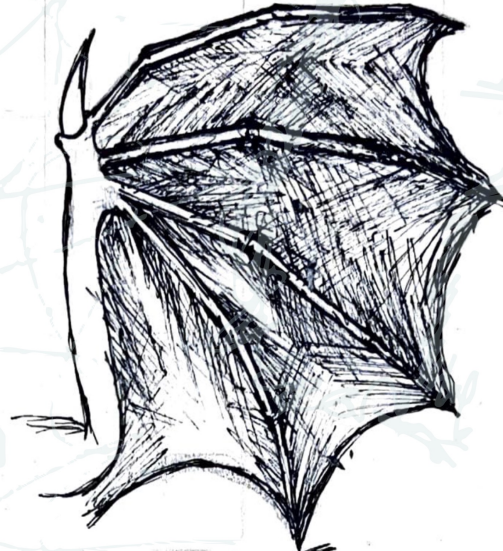

CLOSED WING



MECHANISM

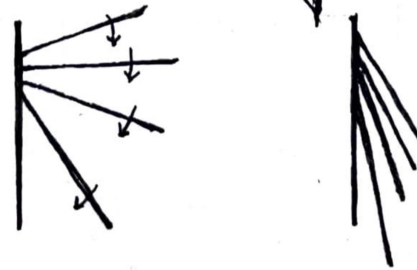

STUDY 1



STUDY 2



STUDY 3



THE DRAGON SKIN PAVILLION, HONG KONG

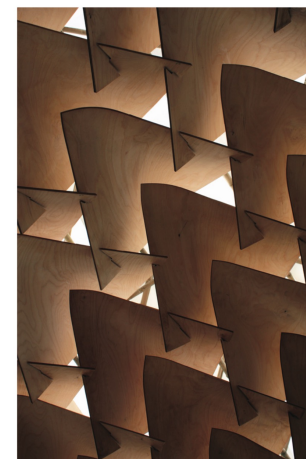
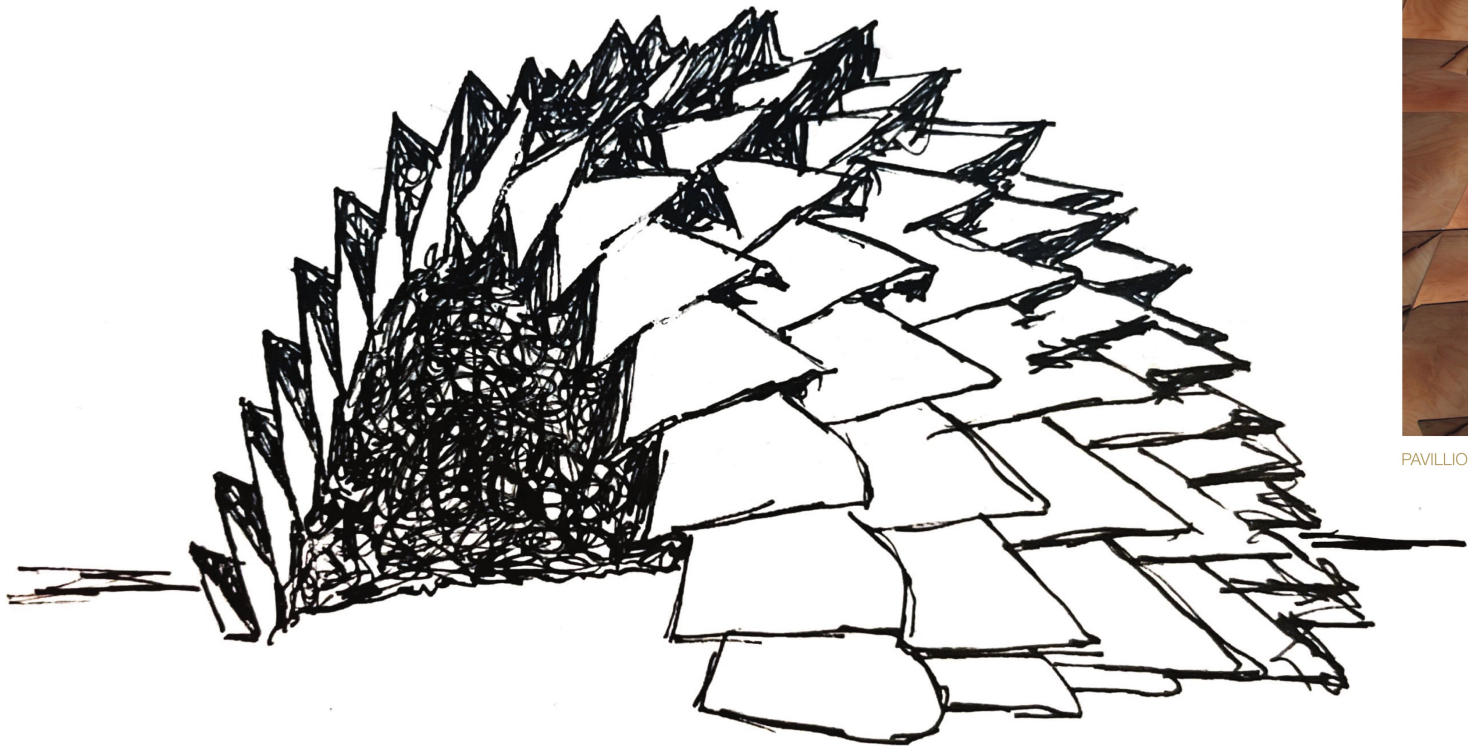

PAVILLION PANEL DESIGN, + ADHESIVE FREE INTERLOCKING

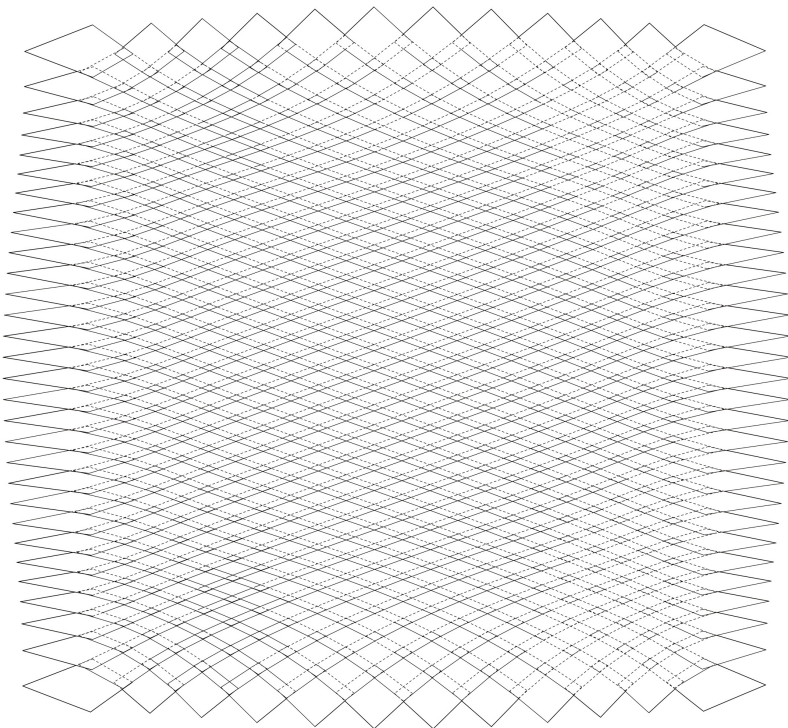
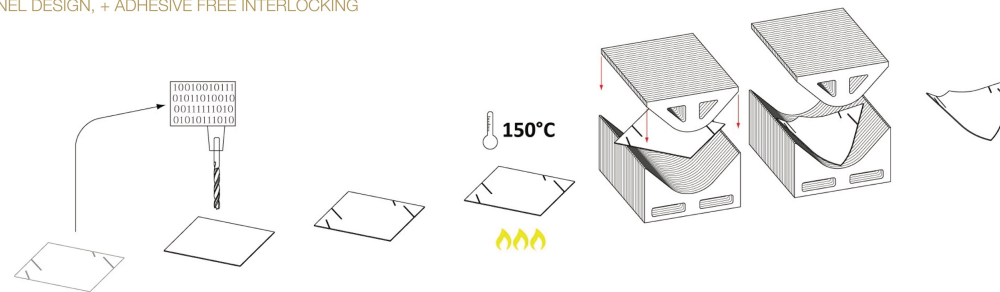

DRAGON SCALE INSPIRED WALL DESIGN

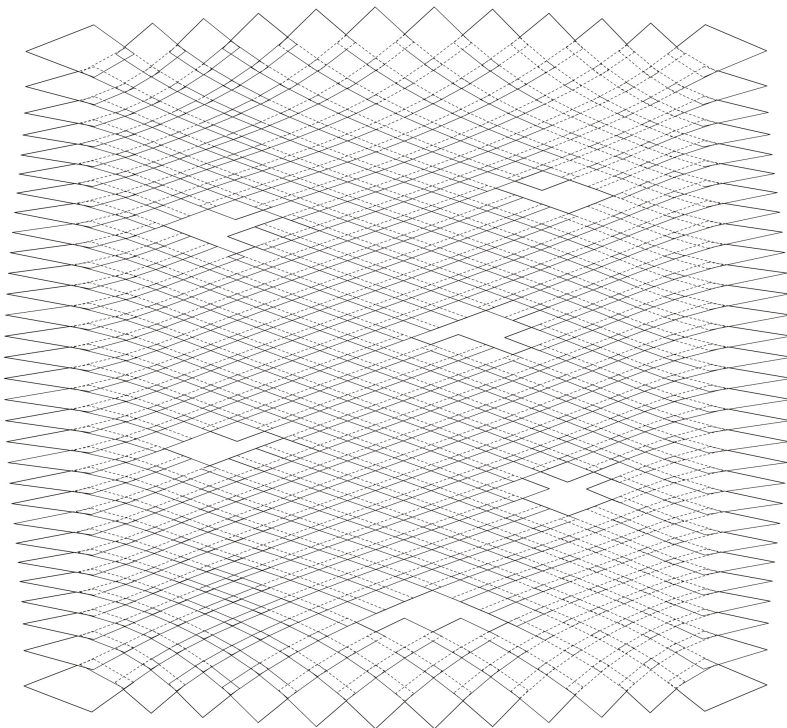

PERFORATING THE WALL

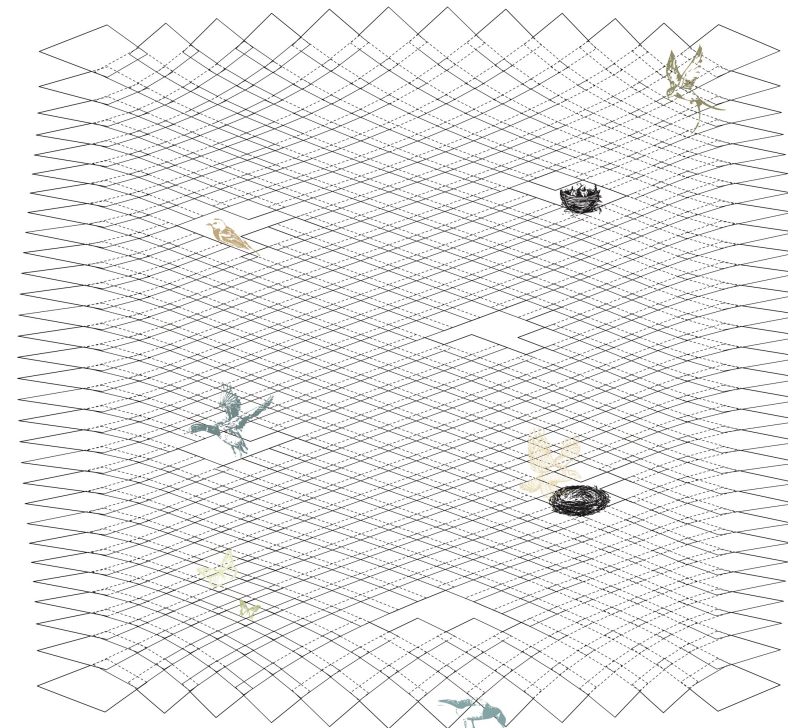

CREATING A BIRD WALL

THE MECHANISM

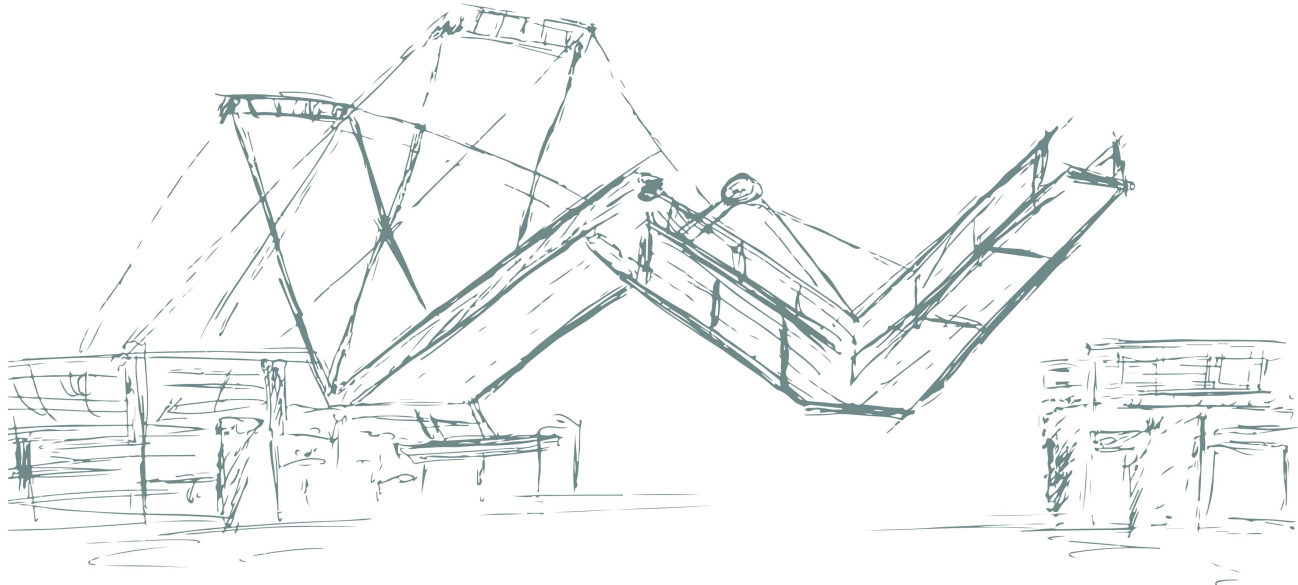

THE HORN BRIDGE, KEIL, GERMANY

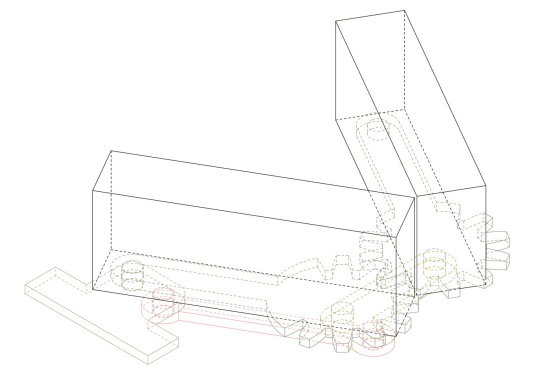
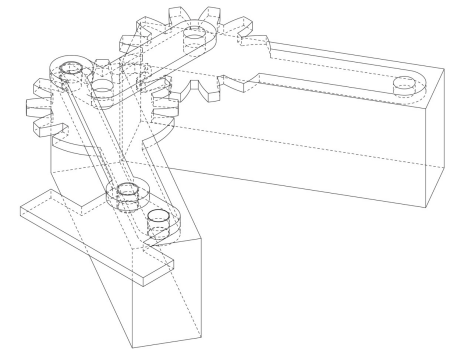
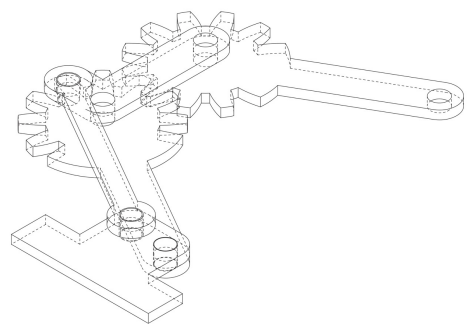
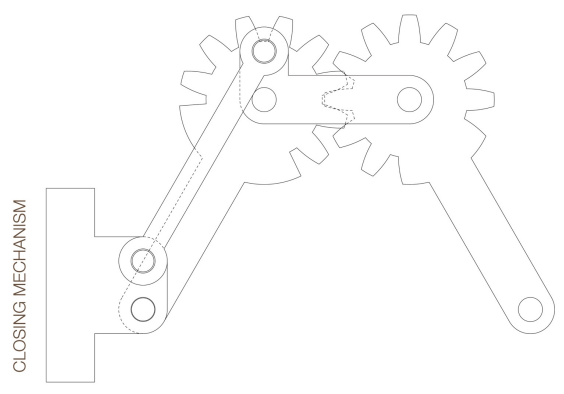
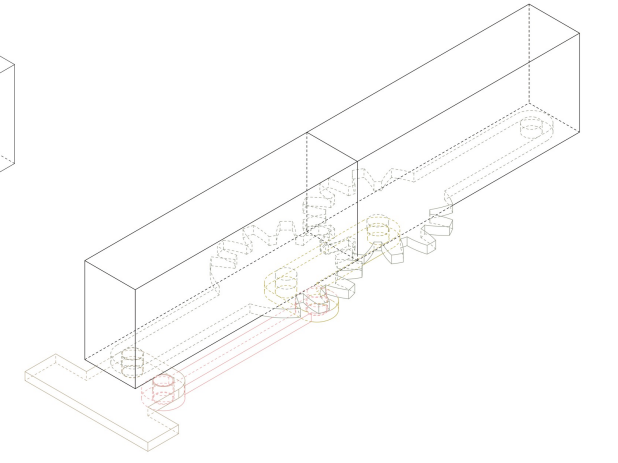
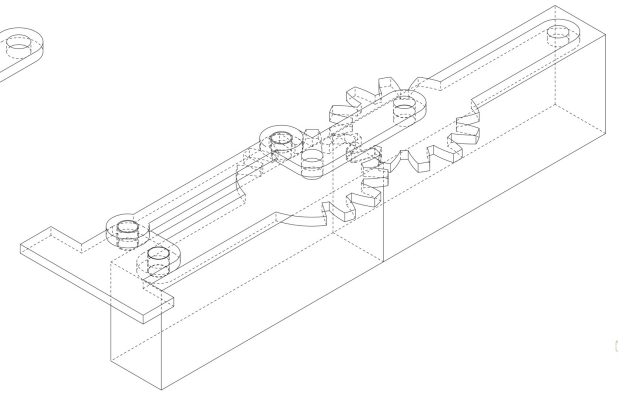
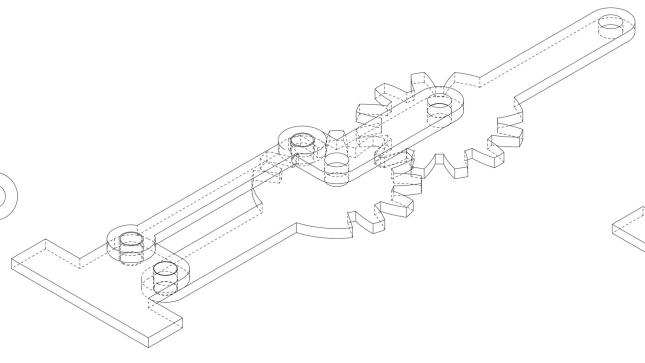
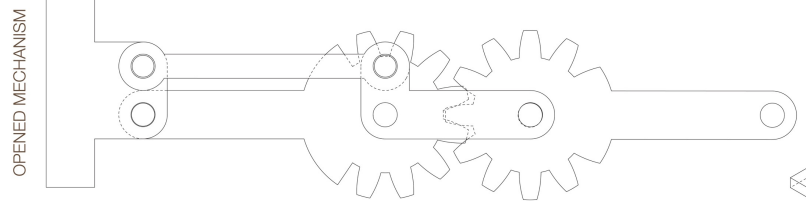

THE LAIR

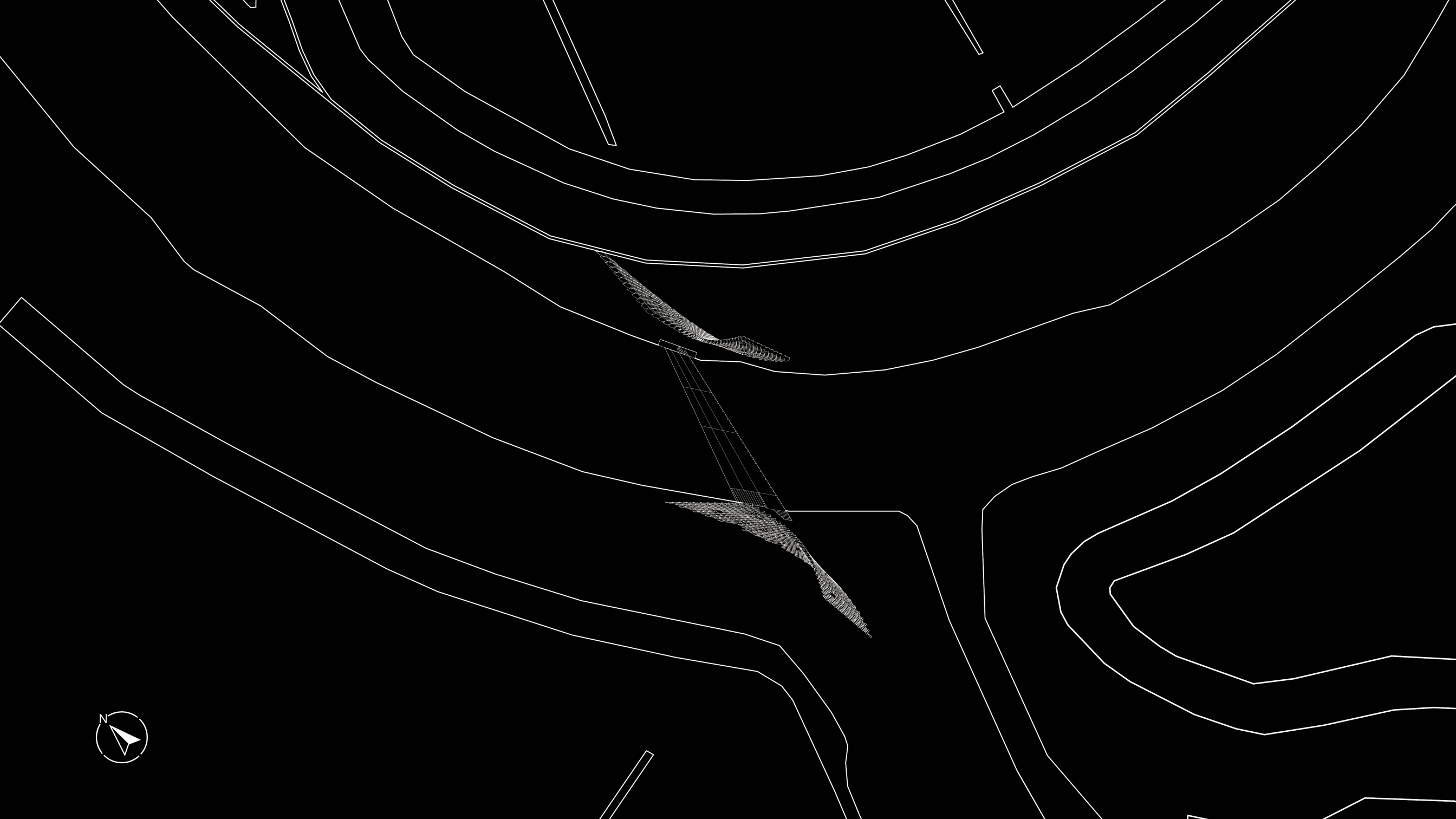

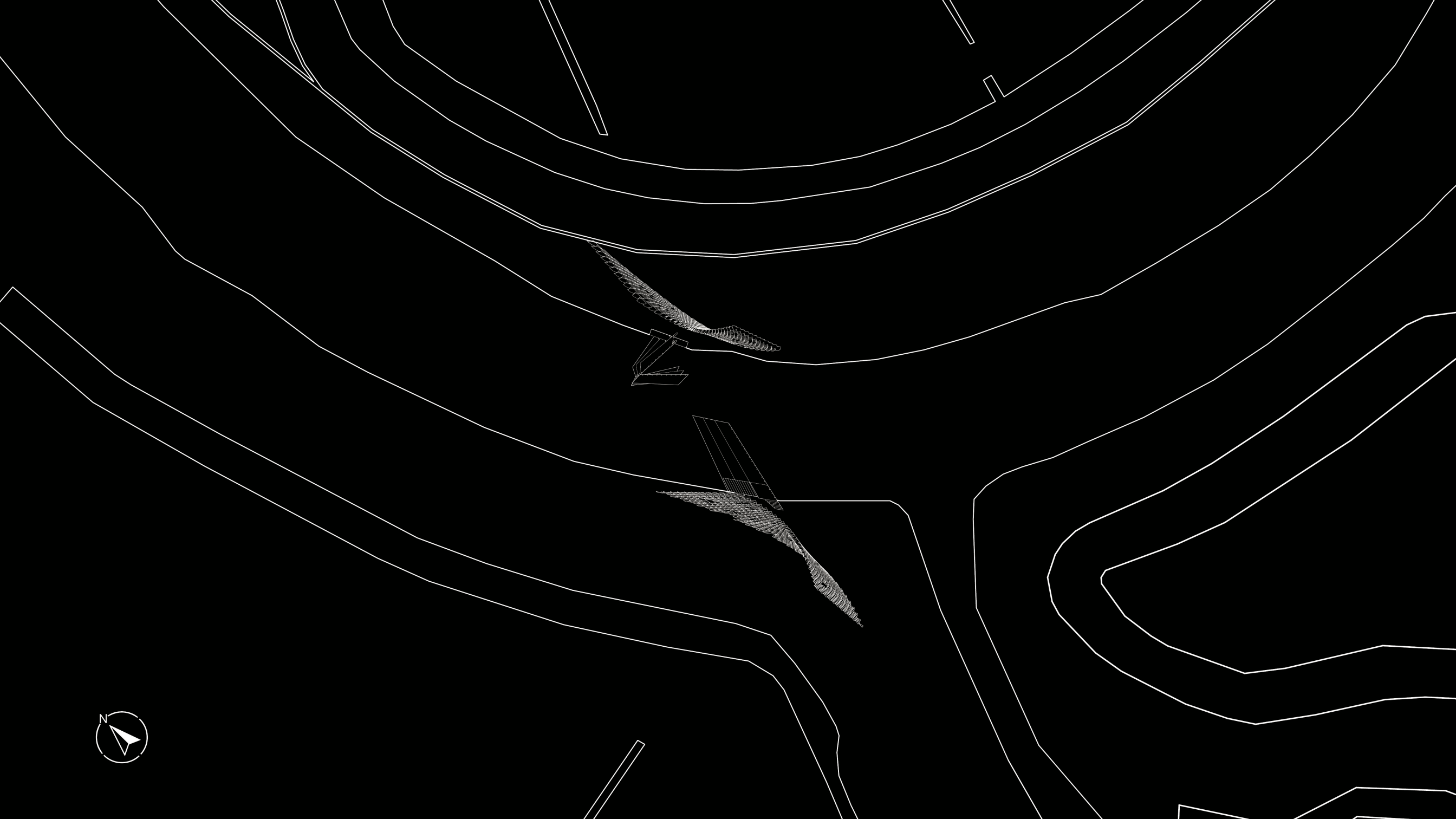

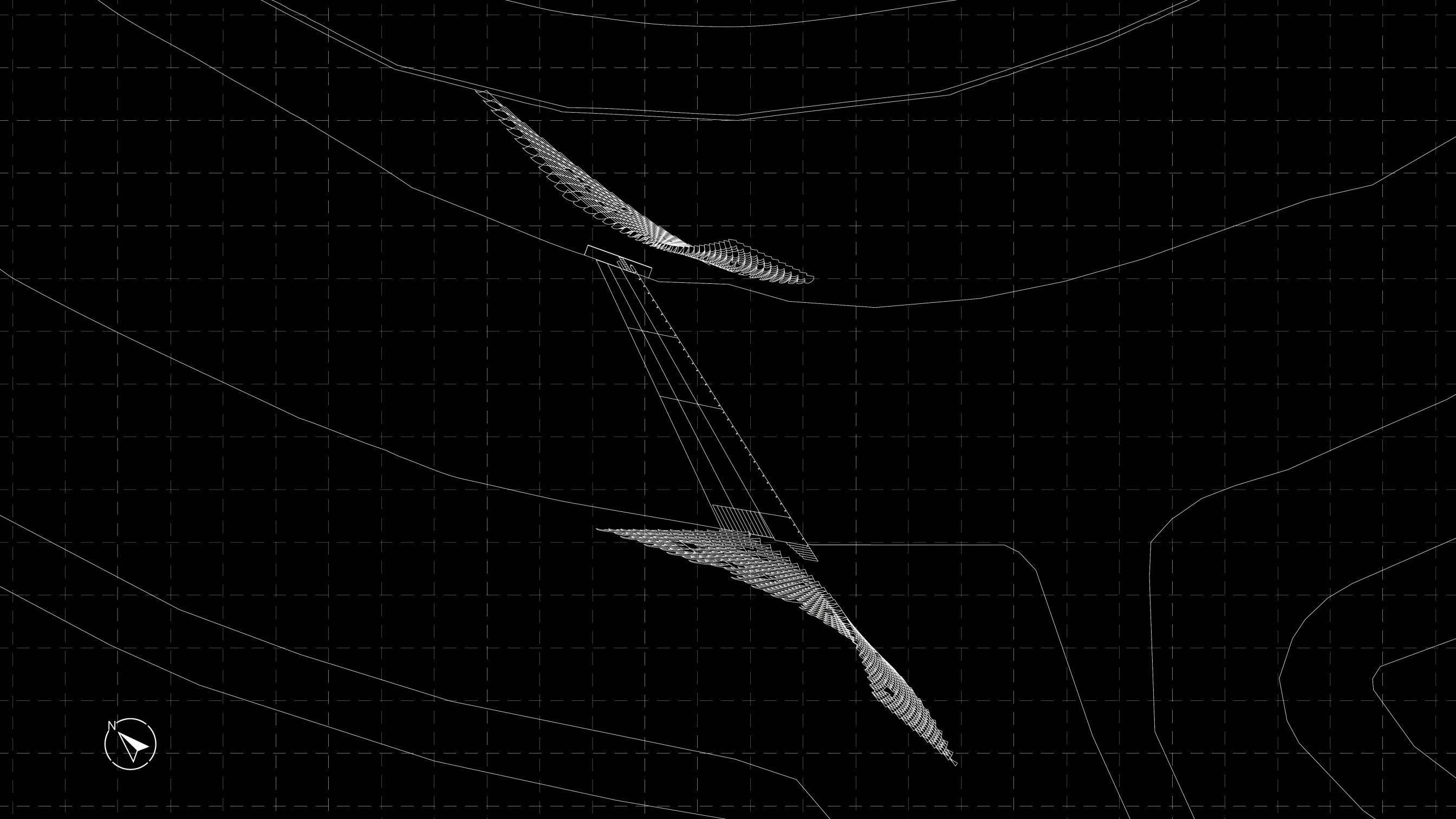

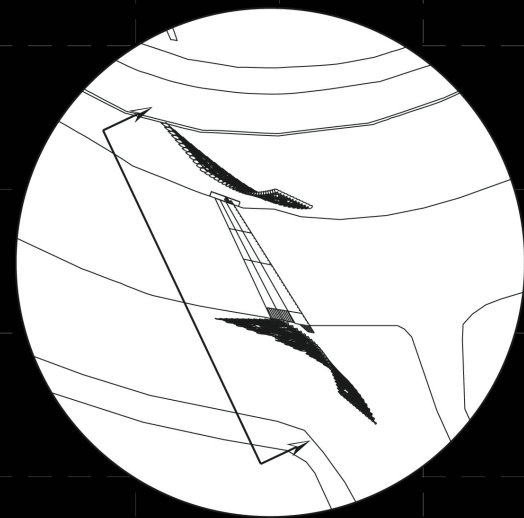
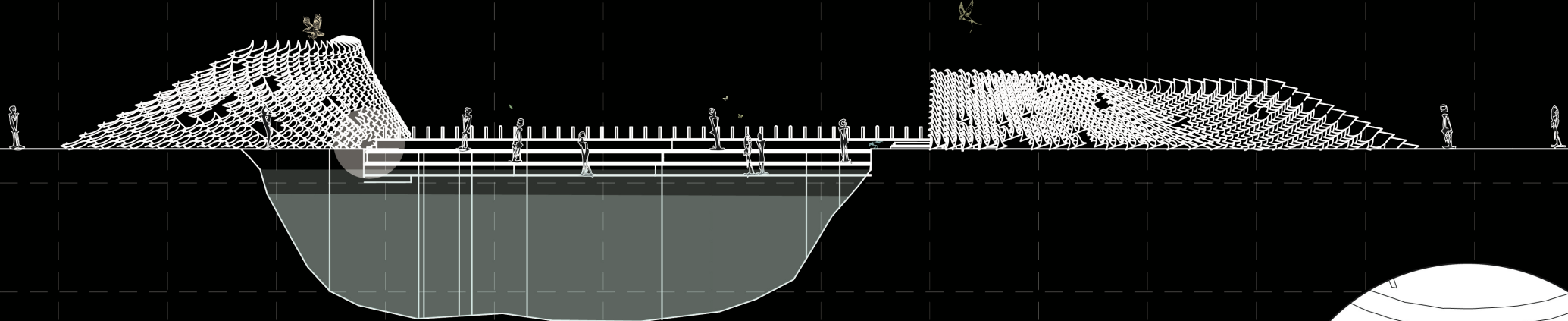
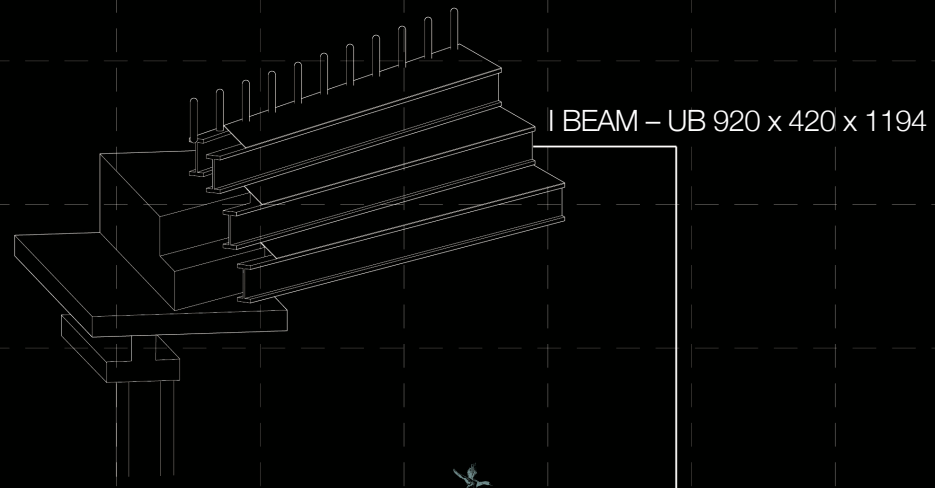

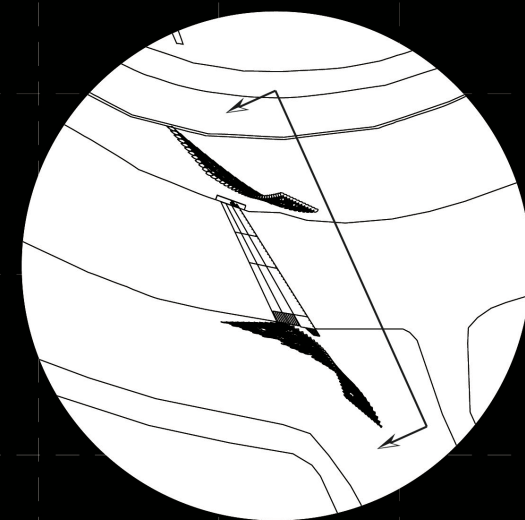
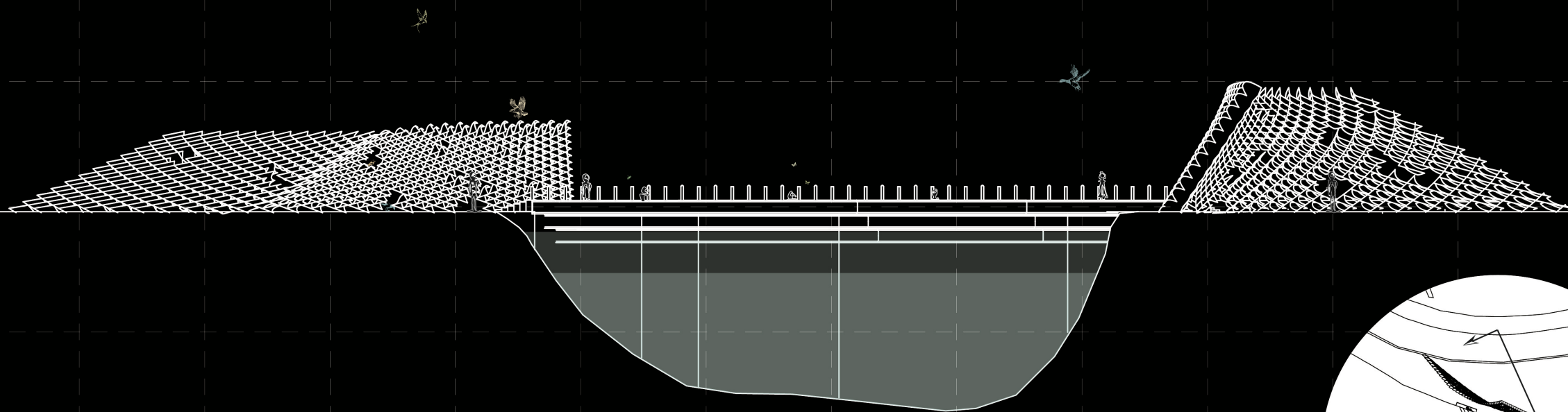

THE TIDES

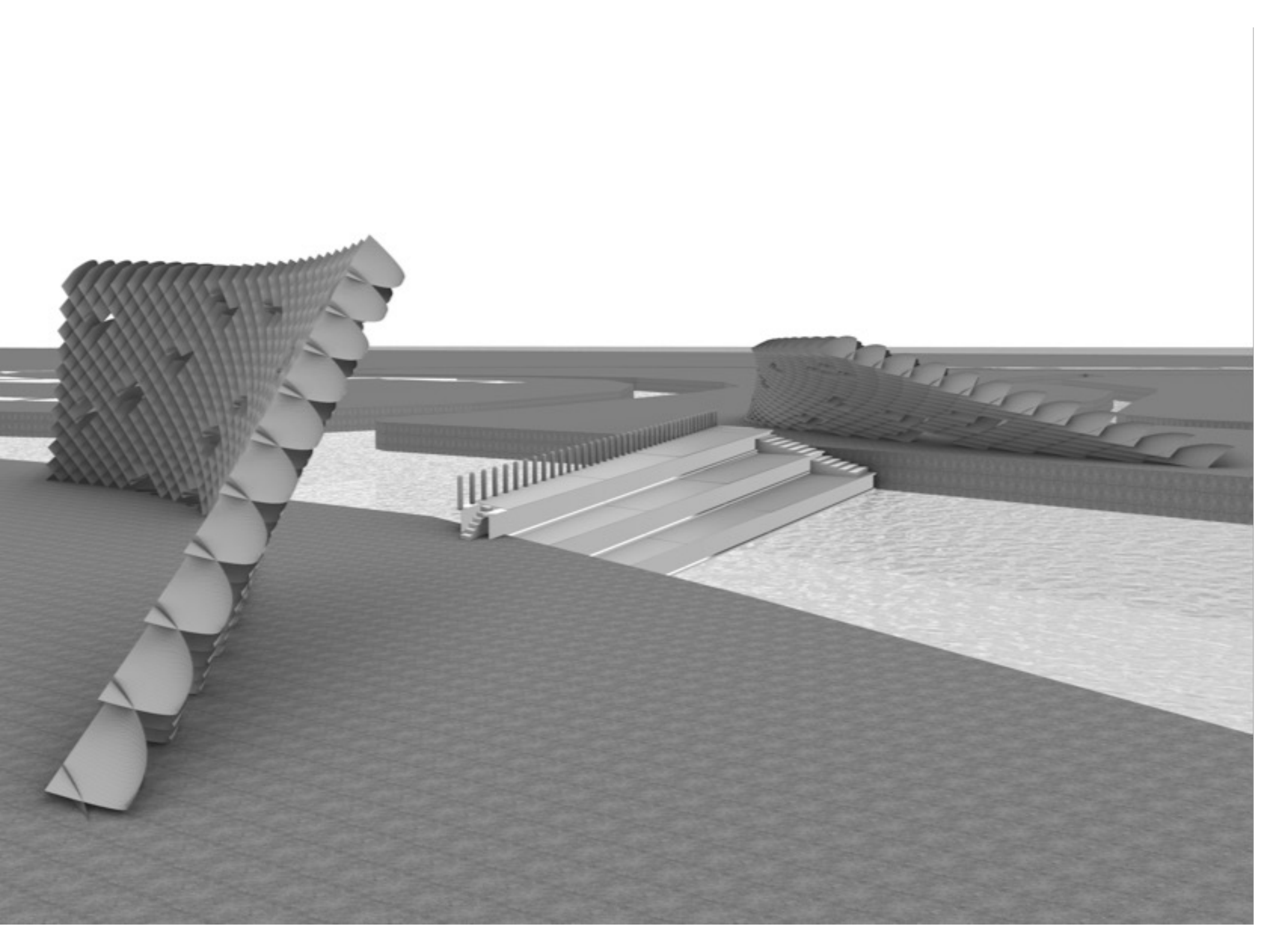

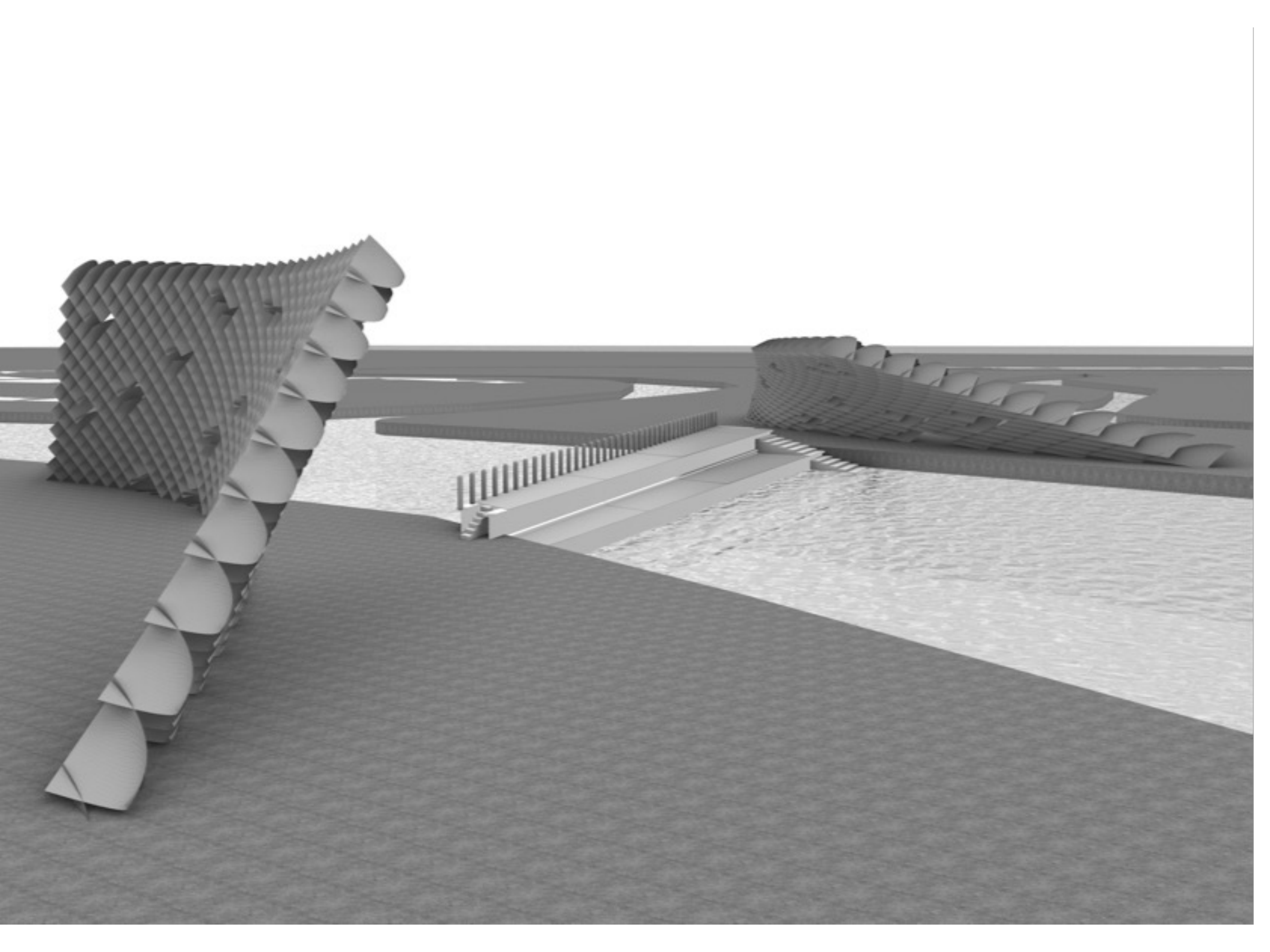

THE LAIR IN 3D

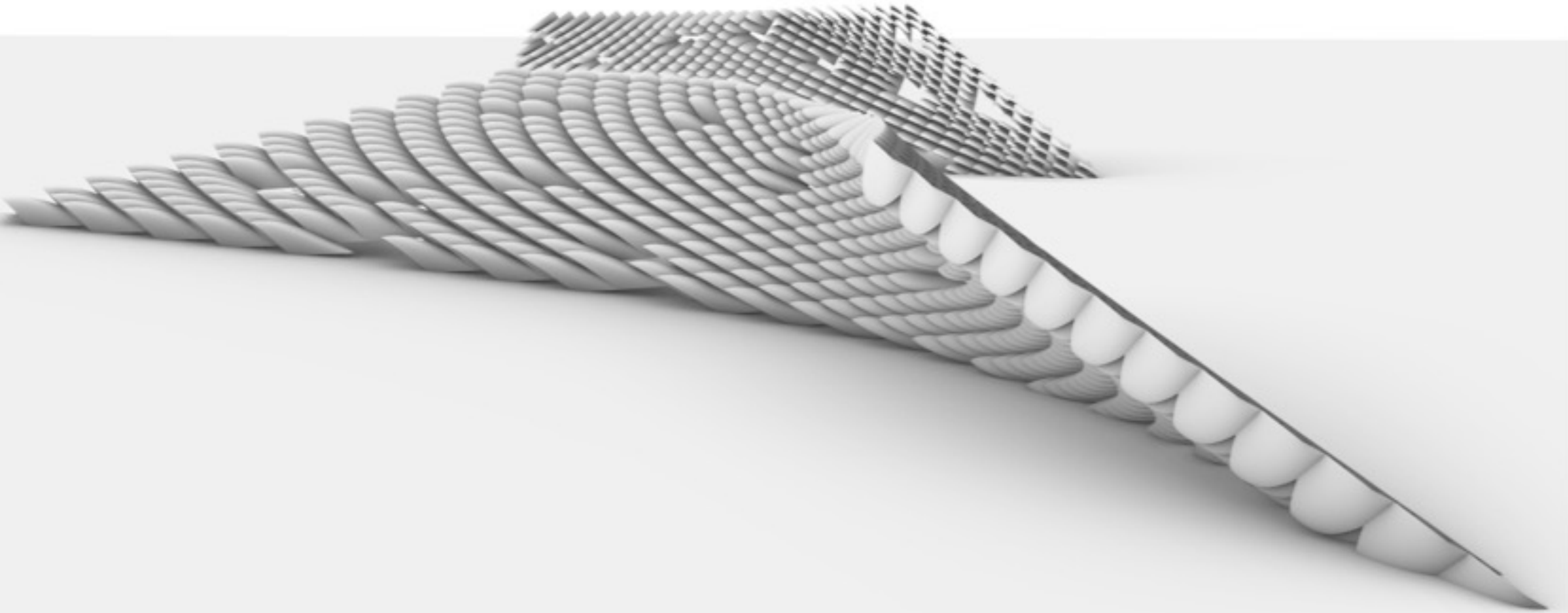
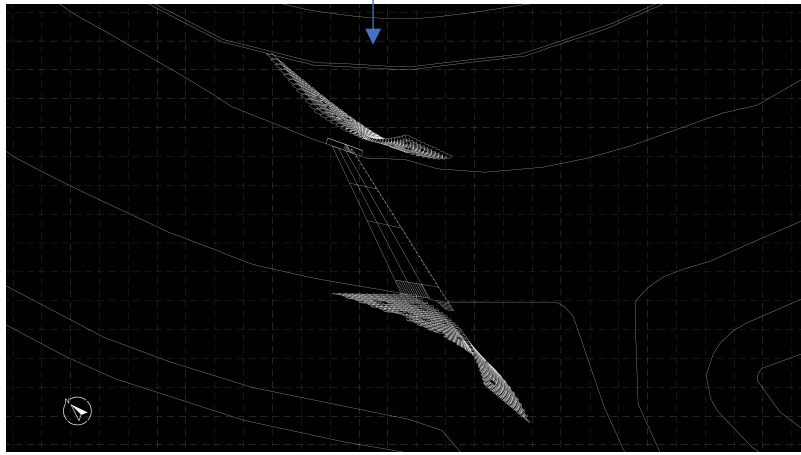

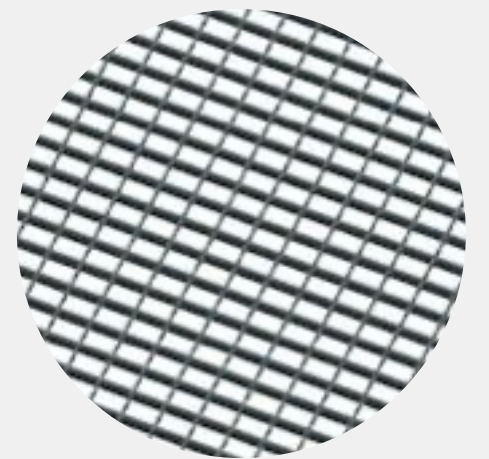
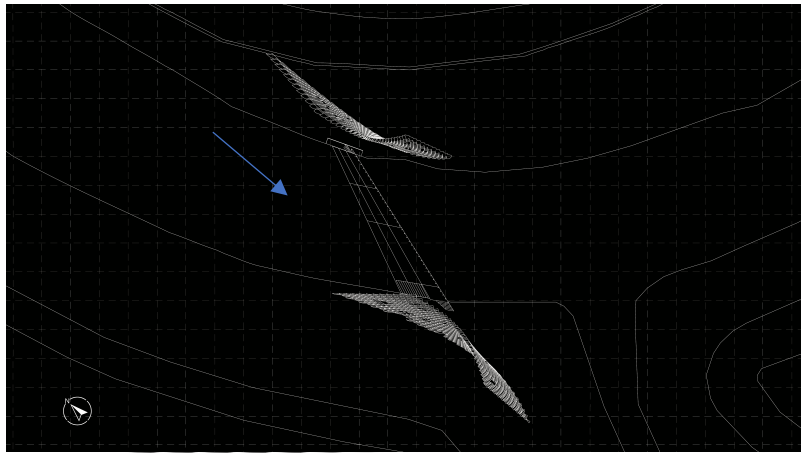

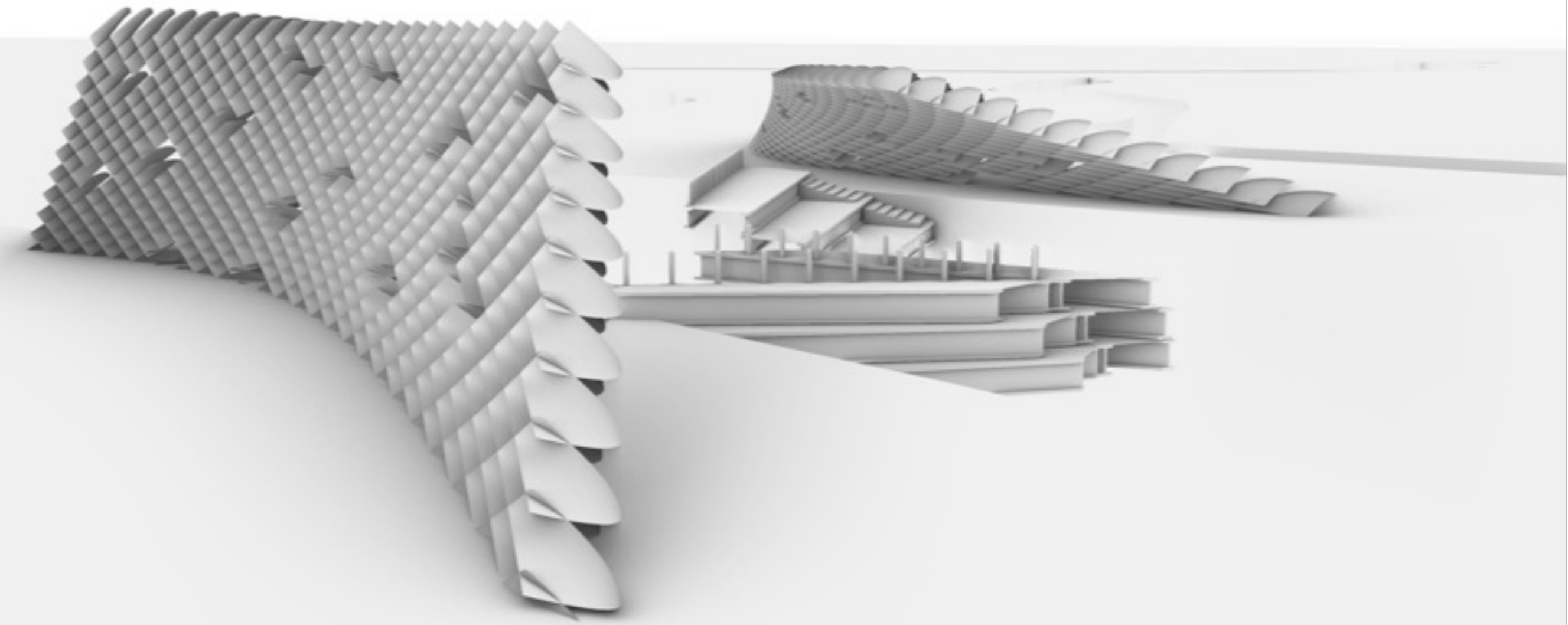

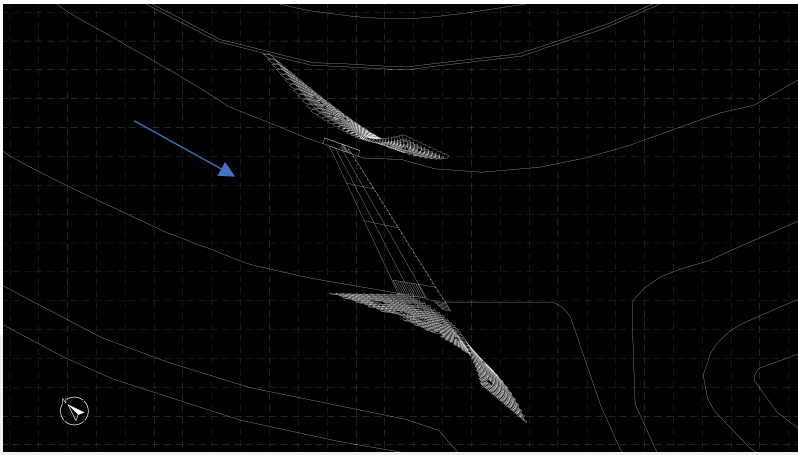

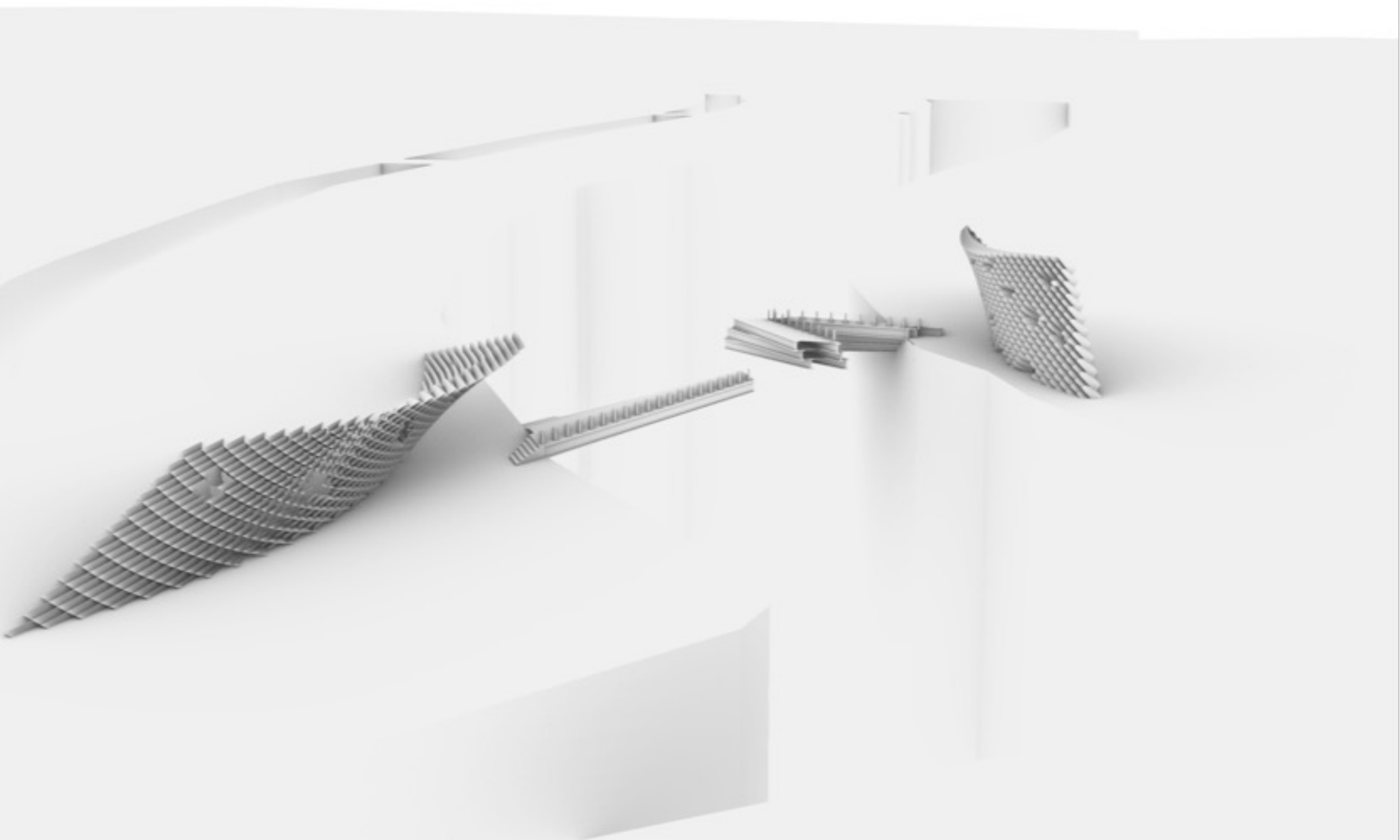

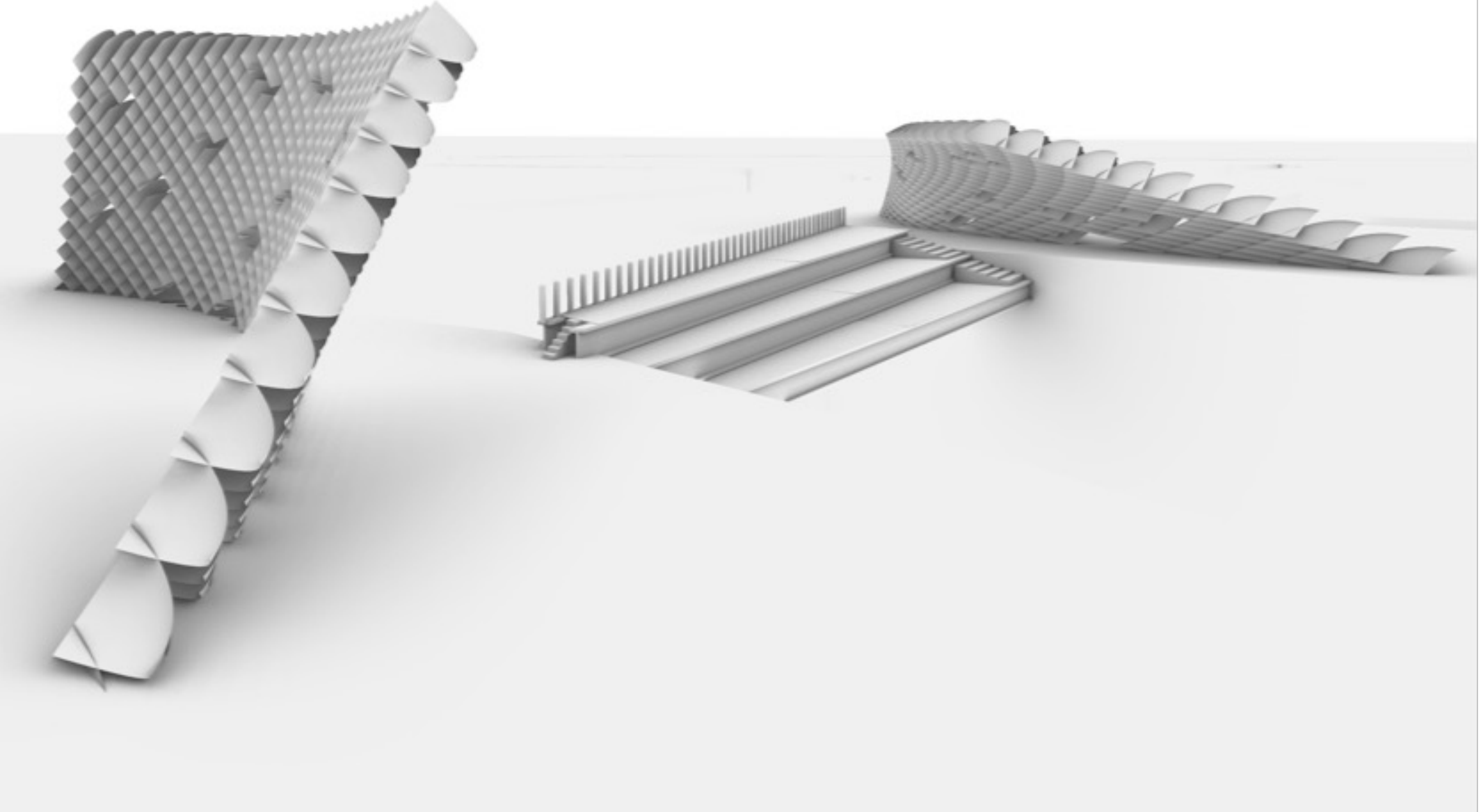
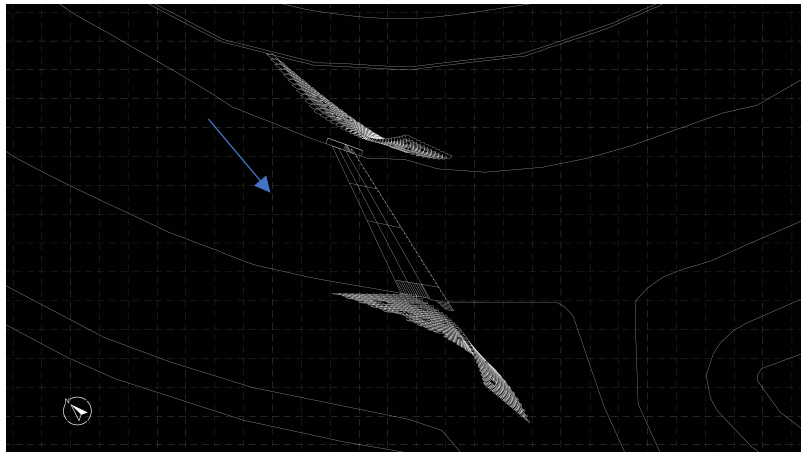

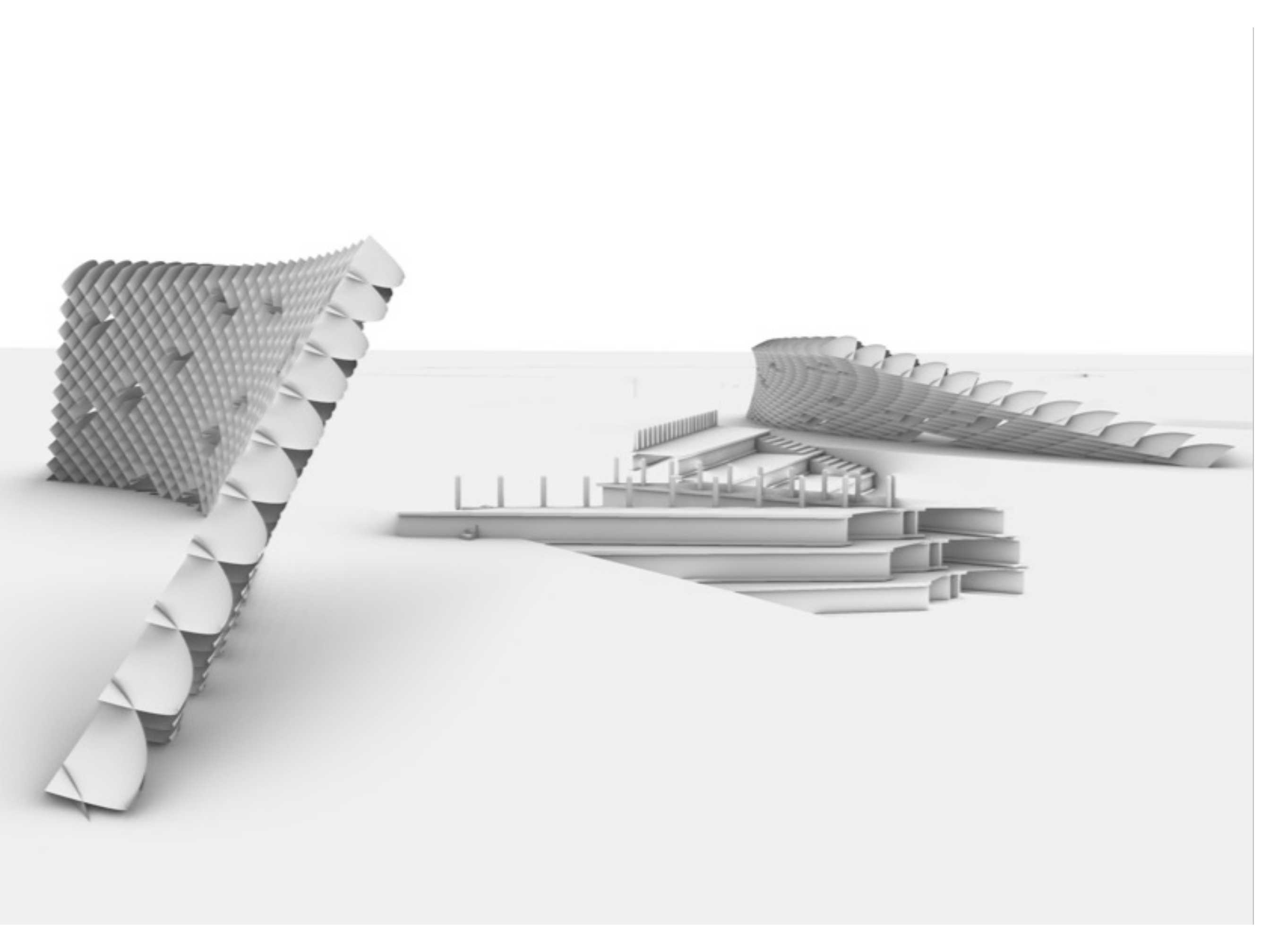

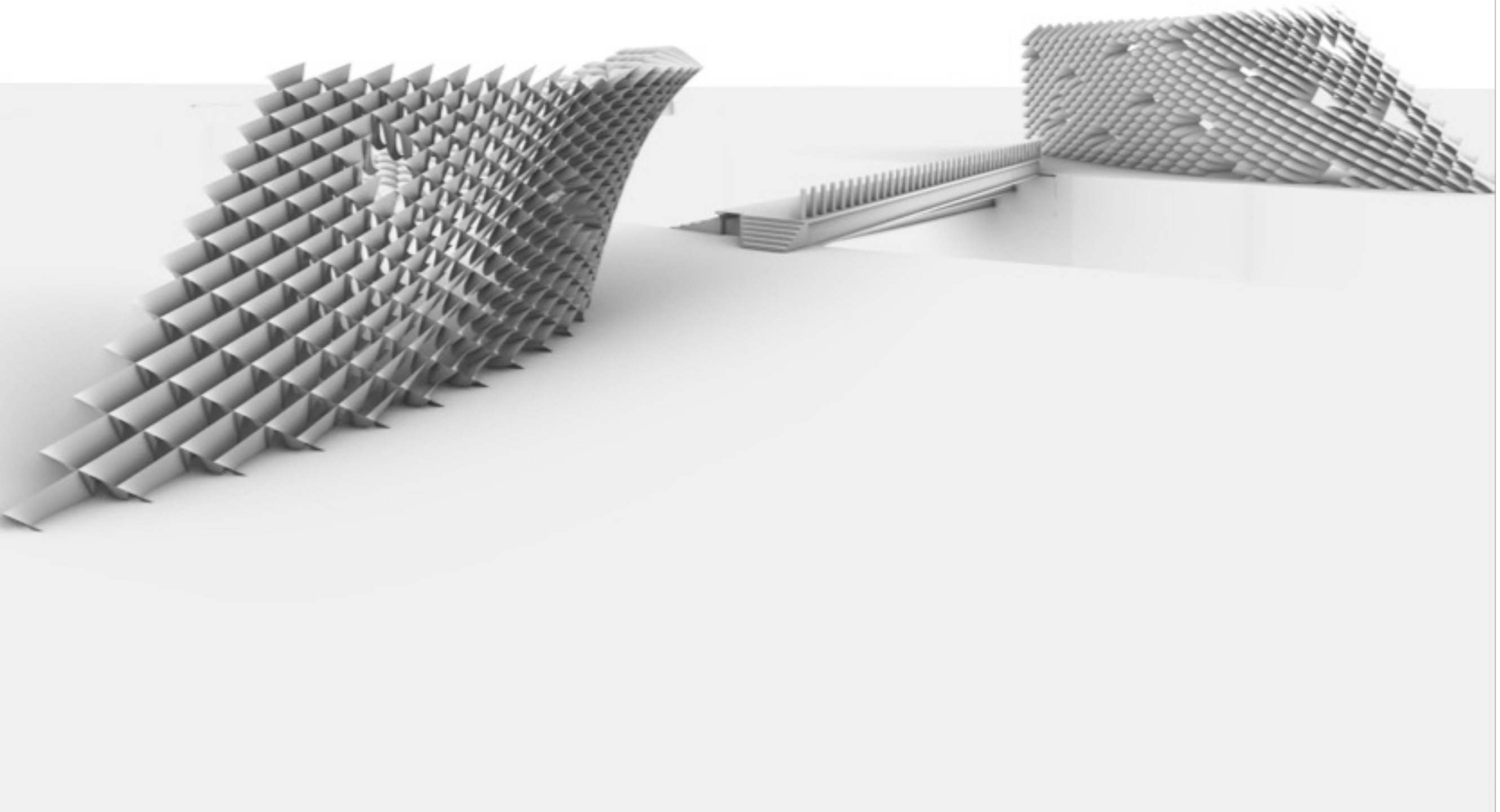
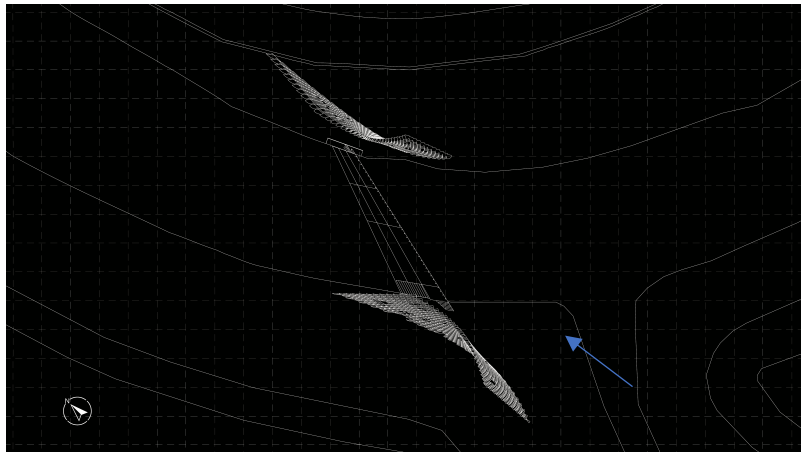

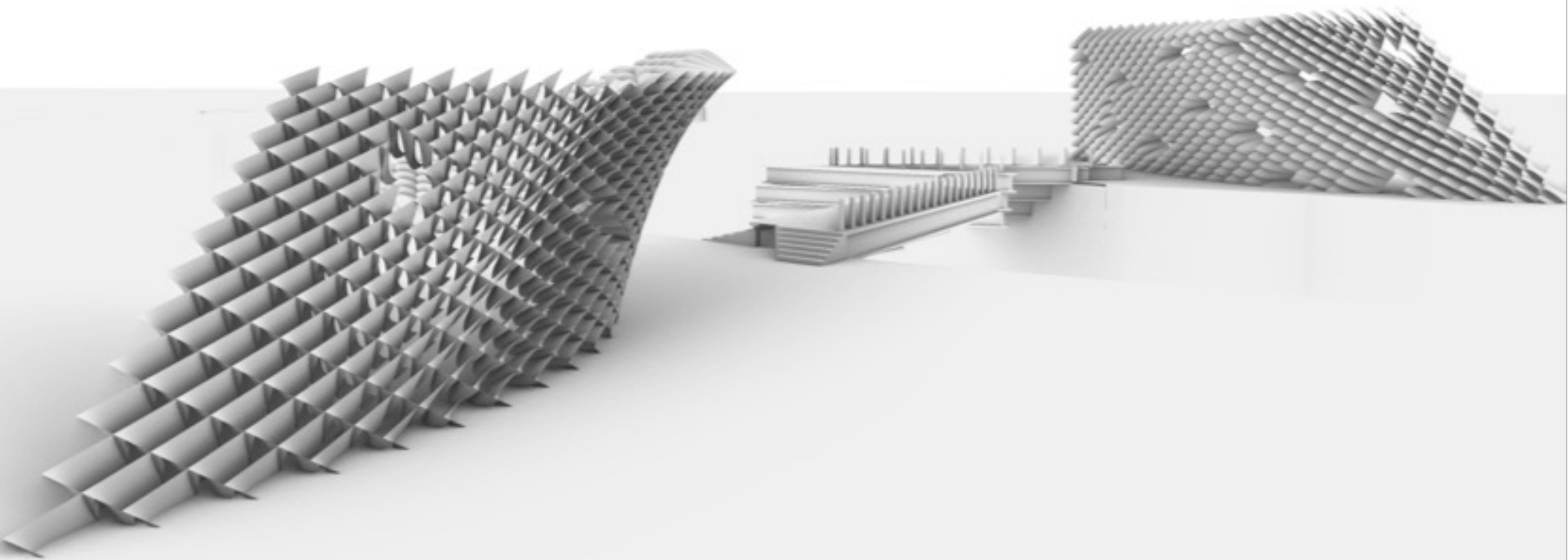

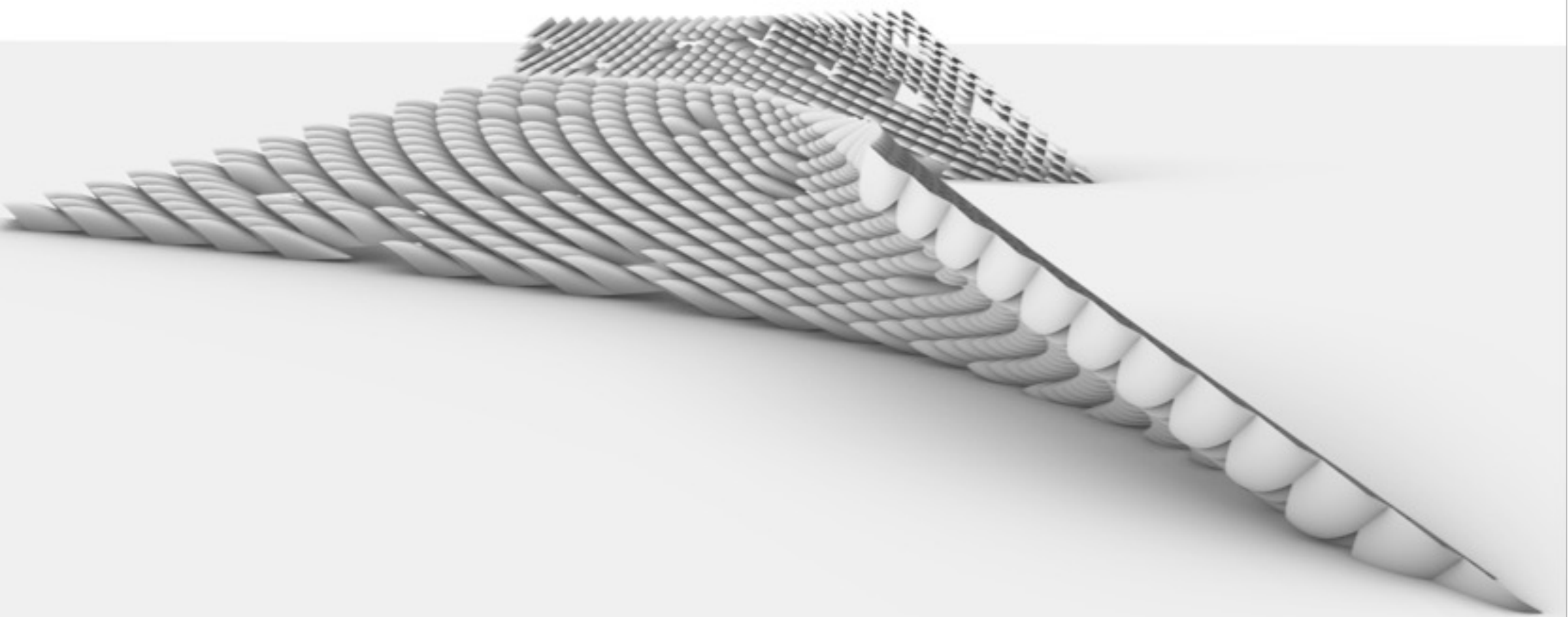

THE LAIR PHYSICAL MODEL

